

Number	Part Number	Name	Quantity
1	23810	46 CUT.DECK NM	1,000
2	23604	INSULATION MUFF	1,000
3	7035	FLAT WASHER	1,000
4	23623	SPRING SHAFT	1,000
5	22065	WASHER 25X8,5X3	1,000
6	24617	THERMAL PROTECTION	1,000
7	24005	ENGINE WASHER	1,000
10	20520	BOLT 8X45	1,000
11	20021	WASHER 8,5X40X4	1,000
12	71074	NUT HM8	1,000
13	23609	PULLEY DIA.46 NG46	1,000
14	5353	SCREW	1,000
15	24616	THERMAL COUPL.22,2	1,000
16	24618	COUPLING DISK	1,000
17	23002	SHEAR WASHER	1,000
18	PZ46E	BLADES FOR PRO 46CM	1,000
19	7341	FLAT WASHER 10,3X49	1,000
20	71052	SPRING WASHER,DIN 1	1,000
21	7342	BOLT 3/8 - 24	1,000
22	23271	WHEEL ASSY 180GREEN	1,000
23	9034	NYLON WASHER	1,000
24	24087	PROTECTION WASHER	1,000
25	71072	BOLT CHC M6X10	1,000
26	20537	WHEEL RING	1,000
29	23324	CUTTING HEIGHT 46	1,000
30	71084	BOLT HM6X16 DIN 933	1,000
31	23056	KNUCKLE SHAFT	1,000
32	71201	NUT M6	1,000
33	24634	DAMPING ELEMENT	1,000
34	20539	FRONT RING	1,000
35	20507	BOLT HM 6X20	1,000
36	24024	BASE SHEET FRONT	1,000
37	2235	WASHER A6.4	1,000
38	71080	SCREW 6X30	1,000
39	23033	GUIDE RING	1,000
40	23024	LINKING ROD FR.REAR	1,000
41	24632	46CUT.HEIGHT SPRING	1,000
42	23028	LINKING ROD	1,000
43	71025	SCREW HM5X18	1,000
44	20564	WASHER 5,5	1,000
45	37561	NUT	1,000

Number	Part Number	Name	Quantity
46	71096	WASHER B6,4	1,000
47	23029	KNUCKLE RING	1,000
48	23027	ROD 46	1,000
49	23335	HEIGHT REAR RIGHT	1,000
50	71076	NUT VERBUS HM8	1,000
51	24083	CORNER RING	1,000
52	24022	CLAMPING BOW	1,000
53	71122	SCREW 8X20	1,000
54	23032	SLOW SHAFT NG 46	1,000
55	24274	CUT.HEIGHT REAR L51	1,000
56	9022	BALL BEARING 6002	1,000
57	24692	SEALING WASHER	1,000
58	24633	GUIDE RING	1,000
59	43187	REAR WHEEL COVER TR	1,000
60	71016	WASHER 16X22X1	1,000
61	5019	GUIDE RING	1,000
62	5733	FREE WHEEL RIGHT	1,000
63	21609	PIN 5X22	1,000
64	5329	CLICK SPRING	1,000
65	5734	FREE WHEEL LEFT	1,000
66	5323	GEAR	1,000
67	24067	WASHER	1,000
68	71021	SCREW FHC/90 M6X12	1,000
69	23275	REAR WHEEL KIT TR.	1,000
70	23811	INDEXED DISK 46	1,000
71	71118	SCREW 8X35	1,000
72	71070	SCREW 8X30	1,000
73	24439	LEVER + SCREW	1,000
74	21177	BALL M8	1,000
75	20548	NAIL RIVET 6X15	1,000
76	7335	WASHER	1,000
77	23605	BLACK COVER	1,000
78	71048	BOLT EJ.PT KA40X10	1,000
79	23041	RING	1,000
81	7094	FLAT WASHER	1,000
82	20693	HEX.SCREW HM6X25	1,000
83	24038	REAR SHEET	1,000
84	23812	BELT COVER 46 WHITE	1,000
85	6178	CLIP NUT	1,000
86	21437	SCREW	1,000
88	22029	FLAT WASHER 6,5	1,000

Number	Part Number	Name	Quantity
89	71135	SCREW 5X25	1,000
90	23075	SPRING SUPPORT	1,000
91	24647	SPRING	1,000
92	24132	SHAFT WASHER	1,000
93	71222	SCREW FHC/90 6X12	1,000
94	24922	WHEEL FLASK 180 GR.	1,000
95	23626	DECK FLAP 46	1,000
96	24602	BASE PLATE BLACK	1,000
97	71206	BOLT EJ.PT KA50X16	1,000
98	21436	CLIPS NUT	1,000
99	23724	LOW COVER 46	1,000
100	23004	SPACER BELT COVER	1,000
101	22031	SCREW 8X55	1,000
105	23631	BELT SPZ 837 MM	1,000
106	23712	WHITE INTERFACE 46	1,000
107	23607	DEFLECTOR QUARD 46	1,000
108	23005	ROD	1,000
110	23614	STRAP NG46 + ROD	1,000
111	23414	DEFLECTOR GREEN CPL	1,000
113	23303	TUBE + RAIL ASSY	1,000
114	23612	INSULATION	1,000
116	9071	SCREW M8X20	1,000
117	5041	BOLT 8X30	1,000
118	5347	SCREW 8X25	1,000
119	24628	PROTECTING CAP HM6	1,000
120	6187	SCREW	1,000
129	21270	WASHER 6,4	1,000
133	71054	EJOT SCR.PT K50X22	1,000
134	23072	BASE RING NG 46	1,000
135	24058	SUPPORT VARIATOR	1,000
136	24085	SPACER PIVOT	1,000
137	24046	VARIATOR PIVOT	1,000
138	24836	RING	1,000
139	23632	PULLEY	1,000
140	24048	VARIATOR SPACER	1,000
144	21256	CIRCLIP	1,000
146	24659	GROOVE PULLEY	1,000
147	24846	SPACER 15X8X5,2	1,000
148	24045	PLATE SUPPORT	1,000
151	23633	BELT 10X5/855LI	1,000
152	23616	COUPLING 25 MM	1,000

Number	Part Number	Name	Quantity
153	23722	INSULATION MUFF	1,000
154	23278	DISC.GEARBOX 46 VAR	1,000
155	23279	DISC.GEARBOX46 ST	1,000

190.01

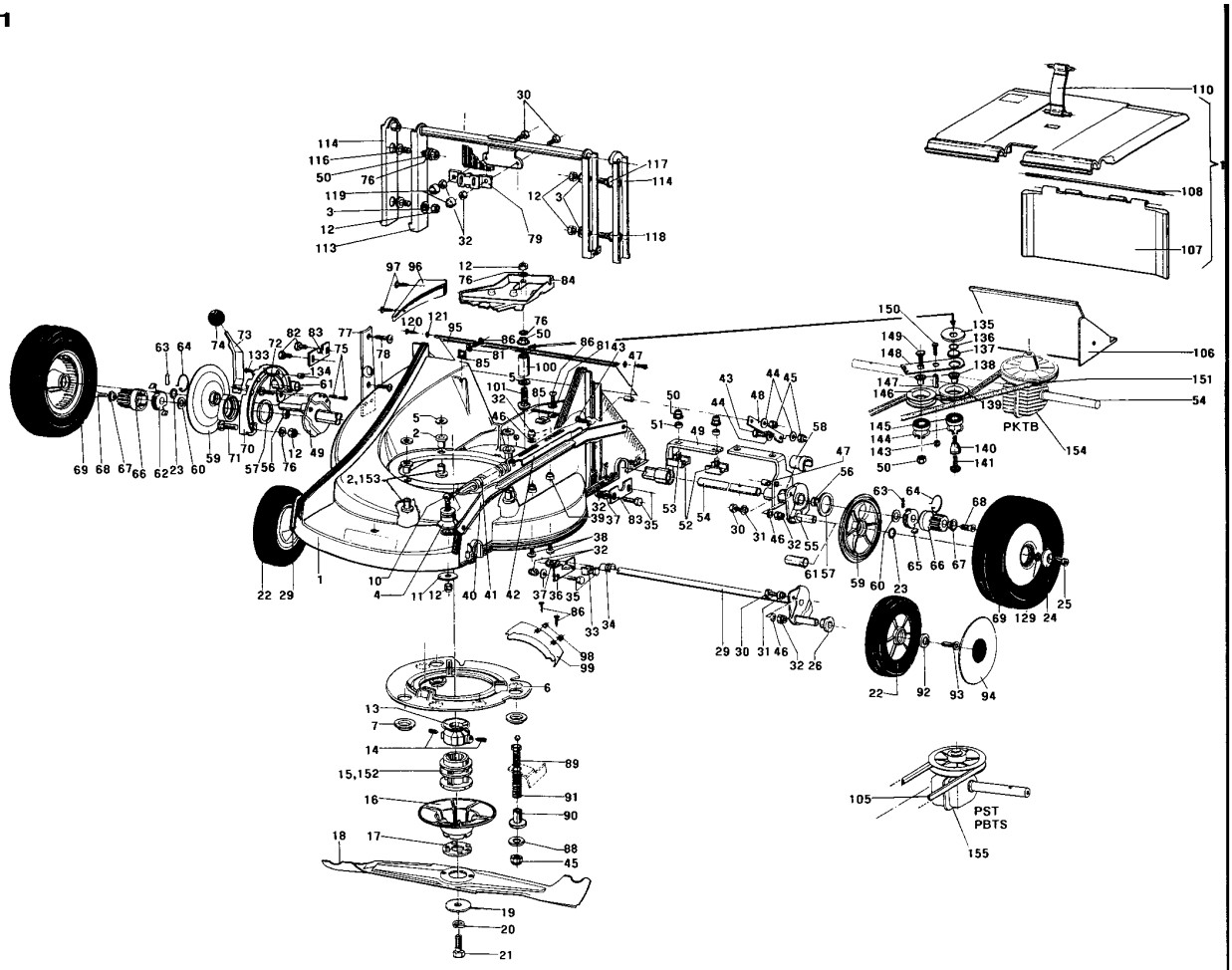

Number	Part Number	Name	Quantity
1	23810	46 CUT.DECK NM	1,000
2	23604	INSULATION MUFF	1,000
3	7035	FLAT WASHER	1,000
4	23615	CAP	1,000
5	24617	THERMAL PROTECTION	1,000
6	24005	ENGINE WASHER	1,000
7	9034	NYLON WASHER	1,000
8	5015	STUDED BUSH	1,000
9	23609	PULLEY DIA.46 NG46	1,000
10	5353	SCREW	1,000
11	24616	THERMAL COUPL.22,2	1,000
12	24618	COUPLING DISK	1,000
13	23002	SHEAR WASHER	1,000
14	PZ46E	BLADES FOR PRO 46CM	1,000
15	7341	FLAT WASHER 10,3X49	1,000
16	71052	SPRING WASHER,DIN 1	1,000
17	7342	BOLT 3/8 - 24	1,000
18	7046	SLEEVE	1,000
19	7047	SLEEVE	1,000
20	23275	REAR WHEEL KIT TR.	1,000
21	24087	PROTECTION WASHER	1,000
22	71072	BOLT CHC M6X10	1,000
23	5323	GEAR	1,000
24	24067	WASHER	1,000
25	71021	SCREW FHC/90 M6X12	1,000
26	5733	FREE WHEEL RIGHT	1,000
27	5734	FREE WHEEL LEFT	1,000
28	5329	CLICK SPRING	1,000
29	21609	PIN 5X22	1,000
30	43187	REAR WHEEL COVER TR	1,000
31	7330	WASHER	1,000
32	71016	WASHER 16X22X1	1,000
33	24692	SEALING WASHER	1,000
34	23340	CUTT.H.LEFT DISK RE	1,000
35	9022	BALL BEARING 6002	1,000
36	23025	INDEXED PLATE	1,000
37	5016	EXT. TRUARC RING	1,000
38	5067	WASHER BELLEVILLE	1,000
39	71070	SCREW 8X30	1,000
40	23070	FRONT LINKING SHAFT	1,000
41	23339	CUTT.H.RIGHT DISC R	1,000

Number	Part Number	Name	Quantity
42	23271	WHEEL ASSY 180GREEN	1,000
43	24669	ABSORBER SPRING	1,000
44	23062	SPACER DIA 12	1,000
45	71092	SCREW HM6-85,8.8	1,000
46	23730	PULLEY	1,000
47	23729	TAPERLOCK PULLEYD25	1,000
48	23636	COUPLING 22.2	1,000
49	23418	CUT.HEIGHT R+F LEFT	1,000
50	23419	CUT.HEIGHT R+F RIGH	1,000
51	24020	NOTCHED DISK	1,000
52	20021	WASHER 8,5X40X4	1,000
53	22031	SCREW 8X55	1,000
54	23004	SPACER BELT COVER	1,000
55	71074	NUT HM8	1,000
56	7335	WASHER	1,000
57	23605	BLACK COVER	1,000
58	71048	BOLT EJ.PT KA40X10	1,000
59	5019	GUIDE RING	1,000
60	7094	FLAT WASHER	1,000
61	21270	WASHER 6,4	1,000
62	21437	SCREW	1,000
63	6178	CLIP NUT	1,000
64	23303	TUBE + RAIL ASSY	1,000
65	23612	INSULATION	1,000
66	23041	RING	1,000
67	9071	SCREW M8X20	1,000
68	71076	NUT VERBUS HM8	1,000
69	5041	BOLT 8X30	1,000
70	5347	SCREW 8X25	1,000
71	71084	BOLT HM6X16 DIN 933	1,000
72	71201	NUT M6	1,000
73	24628	PROTECTING CAP HM6	1,000
74	23812	BELT COVER 46 WHITE	1,000
75	22065	WASHER 25X8,5X3	1,000
76	23414	DEFLECTOR GREEN CPL	1,000
77	23614	STRAP NG46 + ROD	1,000
78	23005	ROD	1,000
79	23607	DEFLECTOR QUARD 46	1,000
80	23712	WHITE INTERFACE 46	1,000
81	23631	BELT SPZ 837 MM	1,000
82	71135	SCREW 5X25	1,000

Number	Part Number	Name	Quantity
83	24647	SPRING	1,000
84	23075	SPRING SUPPORT	1,000
85	22029	FLAT WASHER 6,5	1,000
86	37561	NUT	1,000
87	23722	INSULATION MUFF	1,000
88	23620	COUPLING D25	1,000
89	23347	TAPERLOCK KIT D22.2	1,000
90	2235	WASHER A6.4	1,000
93	6187	SCREW	1,000
94	20564	WASHER 5,5	1,000
95	23626	DECK FLAP 46	1,000
96	24602	BASE PLATE BLACK	1,000
97	71206	BOLT EJ.PT KA50X16	1,000
98	23616	COUPLING 25 MM	1,000
105	23633	BELT 10X5/855LI	1,000
135	24058	SUPPORT VARIATOR	1,000
136	24085	SPACER PIVOT	1,000
137	24046	VARIATOR PIVOT	1,000
138	24836	RING	1,000
139	23632	PULLEY	1,000
140	24048	VARIATOR SPACER	1,000
144	21256	CIRCLIP	1,000
146	24659	GROOVE PULLEY	1,000
147	24846	SPACER 15X8X5,2	1,000
148	24045	PLATE SUPPORT	1,000
149	23279	DISC.GEARBOX46 ST	1,000
150	23278	DISC.GEARBOX 46 VAR	1,000



PBTS-PHTS  
PHTB-PKTB-PST

191.01

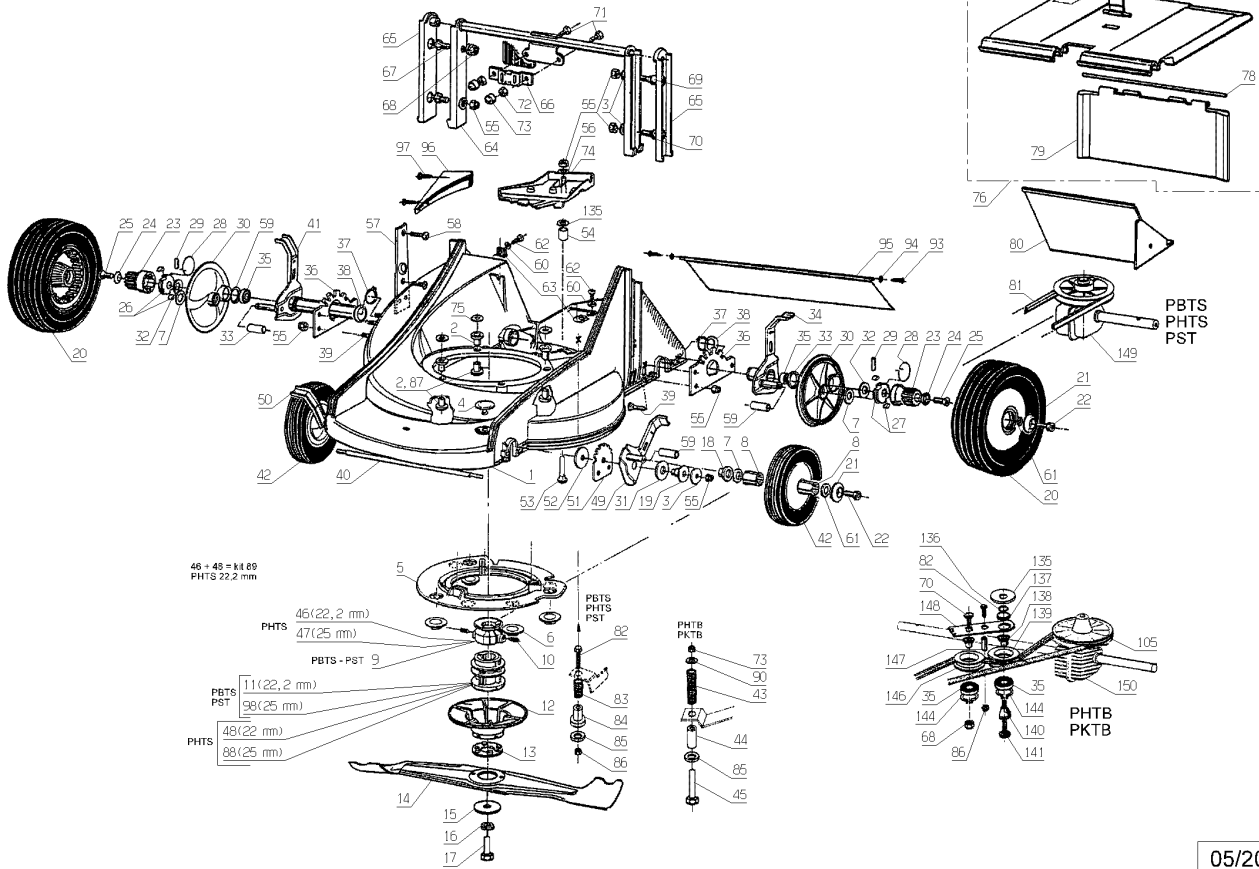

05/2006

Number	Part Number	Name	Quantity
1	23301	LOWER HANDLEBAR	1,000
2	23306	UP. HANDL. ASSY PSE	1,000
3	24014	COLLECTOR HOOK	1,000
4	23014	LOCKING PIN	1,000
5	24610	BUTTON (SMALL)	1,000
6	71074	NUT HM8	1,000
7	2217	BOLT TRCC 8X16	1,000
8	71060	BOLT TRCC 6X25	1,000
9	71201	NUT M6	1,000
10	2235	WASHER A6.4	1,000
11	23653	REMOTE CONTR.SLEEVE	1,000
12	24628	PROTECTING CAP HM6	1,000
13	24614	LOWER LOCKING JOINT	1,000
14	71028	BOLT TRCC 8X110	1,000
15	24629	UPPER LOCKING JOINT	1,000
16	21177	BALL M8	1,000
17	23361	LEVER + SCREWS	1,000
18	23675	THROTTLE CABL+SLEEVE	1,000
19	24683	HALF CAP	1,000
20	24682	COVER	1,000
21	71082	EJOT SCR.PT KA40X12	1,000
22	24433	BLADE EN-/DISENGAGE	1,000
23	24395	ENGINE SPEED MODUL	1,000
24	24050	SLEEVE STOP	1,000
25	71051	BOLT EJ.PT KA40X14	1,000
26	71050	BOLT EJ.PT KA40X14	1,000
27	23651	LOWER HOUSING	1,000
28	23666	CAPSULE	1,000
29	24434	DRIVE EN-/DISENGAGE	1,000
30	23650	CENTRAL HOUSING	1,000
31	24350	LEVER STOP	1,000
33	24690	LOCKING BUTTON	1,000
34	24609	SPRING	1,000
35	24059	BOLT	1,000
36	24684	TRUARC RING	1,000
37	23652	CENTR.HOUSING REAR	1,000
38	23660	DRIVE CABLE+SLEEVE	1,000
39	24778	SPRING	1,000
41	24128	HS MOTOR BRAKE DISK	1,000
42	23703	ENG.-BRAK.TRANS.B&S	1,000
43	23672	THROTTLE CABLE BRIG	1,000

Number	Part Number	Name	Quantity
44	23685	THROTTLECABLE GCV	1,000
50	24700	BUTTON	1,000
51	24670	GUIDE-RECOIL START.	1,000
54	24711	CABLE+SLEEVE VARIAT	1,000
60	24838	SPRING	1,000
61	24354	THROTTLE - SUZUKI	1,000
62	24672	THROTTLE CABLE PKTB	1,000
63	24701	INDEXED DISK	1,000
64	23053	THROTTLE R.PLATE	1,000
65	23723	BLADE CLUTCH CABLE	1,000
66	24758	LEVER SPRING	1,000
67	23700	MOTOR-BRAKE TRAN.	1,000
71	24703	BACK SPRING	1,000
72	24644	VARIATOR SLIDE	1,000
73	24702	LINKAGE	1,000
75	24845	LOCKING ARM	1,000
76	24843	DOUBLE CTRL.SPRING	1,000
77	24844	LOCKING LEVER	1,000
79	24364	GAZ MODULE BRIGGS	1,000
80	71237	SCREW F H M4-8,4.8	1,000
81	21525	NUT HM4	1,000
83	21524	SCREW M8X35	1,000
87	23681	CABLE+SLEEVE CLUTCH	1,000

PBTS-PHTS  
PHTB-PKTB-PST

195.01

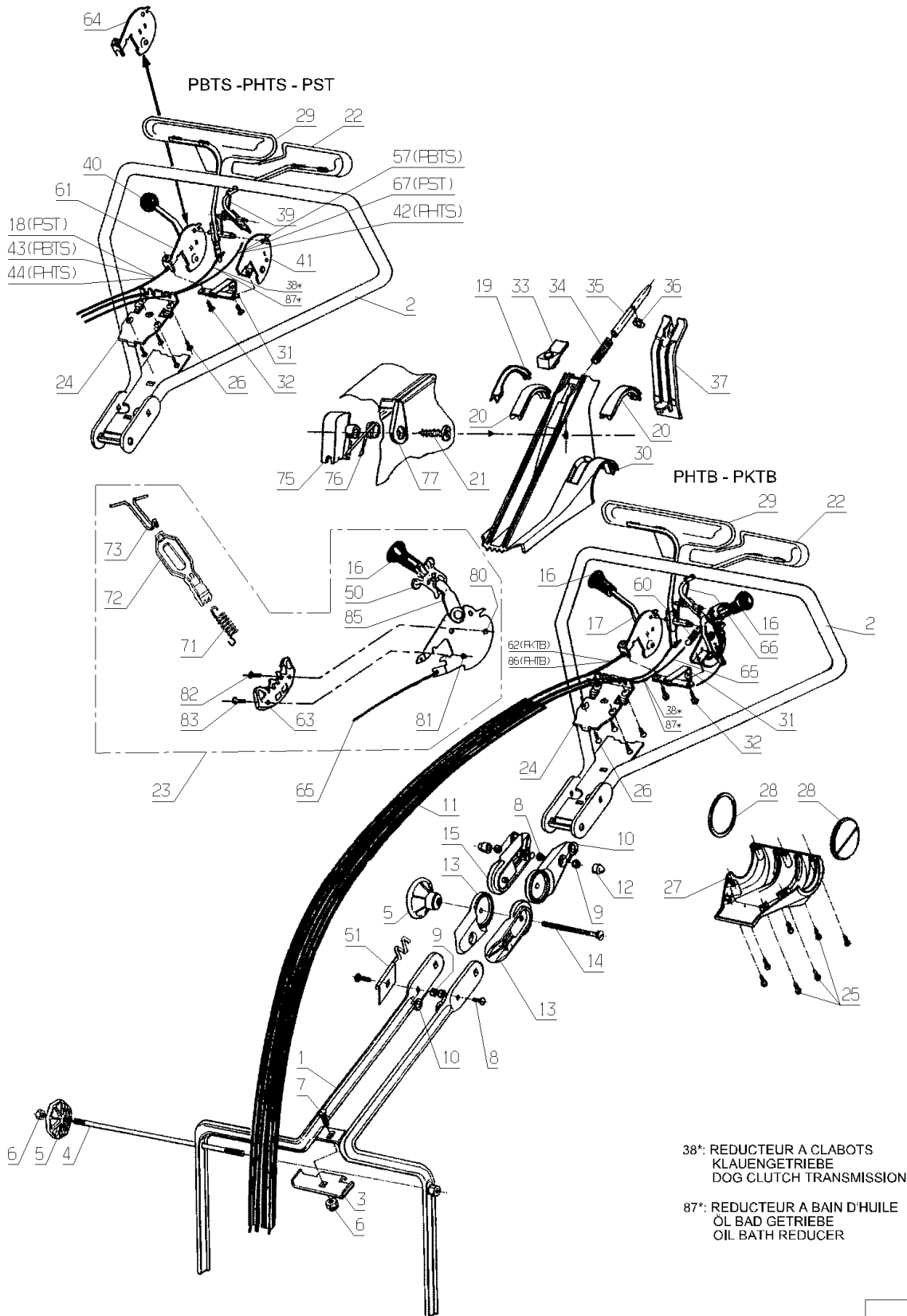

09/2006

Number	Part Number	Name	Quantity
1	42240	OIL BATH VAR. REDUC	1,000
2	71019	CIRCLIP 16X1	1,000
3	24072	WASHER 32X16,5X1	1,000
4	24649	PULLEY STOP	1,000
5	24651	PULLEY SPRING	1,000
6	24044	1/2 PULLEY FLANGE	1,000
7	24665	1/2 PULLEY	1,000
8	24069	GUIDE STUB	1,000
9	37561	NUT	1,000
10	71022	SCREW FHC/90 M5X20	1,000
11	41823	WASHER+AXLE PUL.CPL	1,000
12	24840	1/2 PULLEY	1,000
13	20556	PIN 3X15	1,000
14	22455	REDUCTION GEAR PULL	1,000
15	71088	PIN 3X22	1,000
16	20561	CURLED WASHER A10	1,000
17	21036	FLAT WASHER 10.5	1,000
18	20559	CIRCLIPS 10	1,000
19	41105	CASING REINFORCEMENT	1,000
20	71219	LIP SEAL 15X21X5	1,000
21	24135	SLOW SHAFT NG51 RD	1,000
23	71211	BOLT EJ-PT 50X16	1,000
24	41102	STRIDDED STOP	1,000
25	71216	STOP WASHER	1,000
26	24776	BELL + WHEEL SET	1,000
27	41097	EXT.CLUTCH PLATE	1,000
28	41096	INT.CLUTCH PLATE	1,000
29	71214	WASHER R9	1,000
31	41095	STOP WASHER	1,000
32	41094	FORK RD	1,000
33	41104	CARRIER	1,000
34	21609	PIN 5X22	1,000
35	71220	O-RING 8,9X1,9	1,000
41	41050	-> 41052 + 42095	1,000
42	41051	REDUCT. GEAR COVER	1,000
43	41110	COVER SEAL	1,000
44	20558	RING C/10 15X10	1,000
45	20555	ENDLESS BOLT	1,000
47	41055	QUICK SHAFT N.M	1,000
48	24642	BEARING	1,000
49	71218	LIP SEAL 10X18X4	1,000

Number	Part Number	Name	Quantity
51	41822	PUSH AXLE (SET)	1,000
52	41059	CONTROL ARM	1,000
53	71244	BOLT EJ-PT 50X20	1,000
54	7094	FLAT WASHER	1,000
55	71213	BOLT M4X10	1,000
56	41060	CLUTCH SPRING	1,000
57	42095	BRACKET	1,000
58	41056	SELF LUBRICATE BUSH	1,000
59	23087	SLOW SHAFT 46 RD	1,000
60	24269	OIL BATH RED 1SPEED	1,000
61	24686	SPRING	1,000
62	24275	VARIATOR PULLEY	1,000
63	23278	DISC.GEARBOX 46 VAR	1,000
64	23279	DISC.GEARBOX46 ST	1,000

VIVA 46/51

180.01

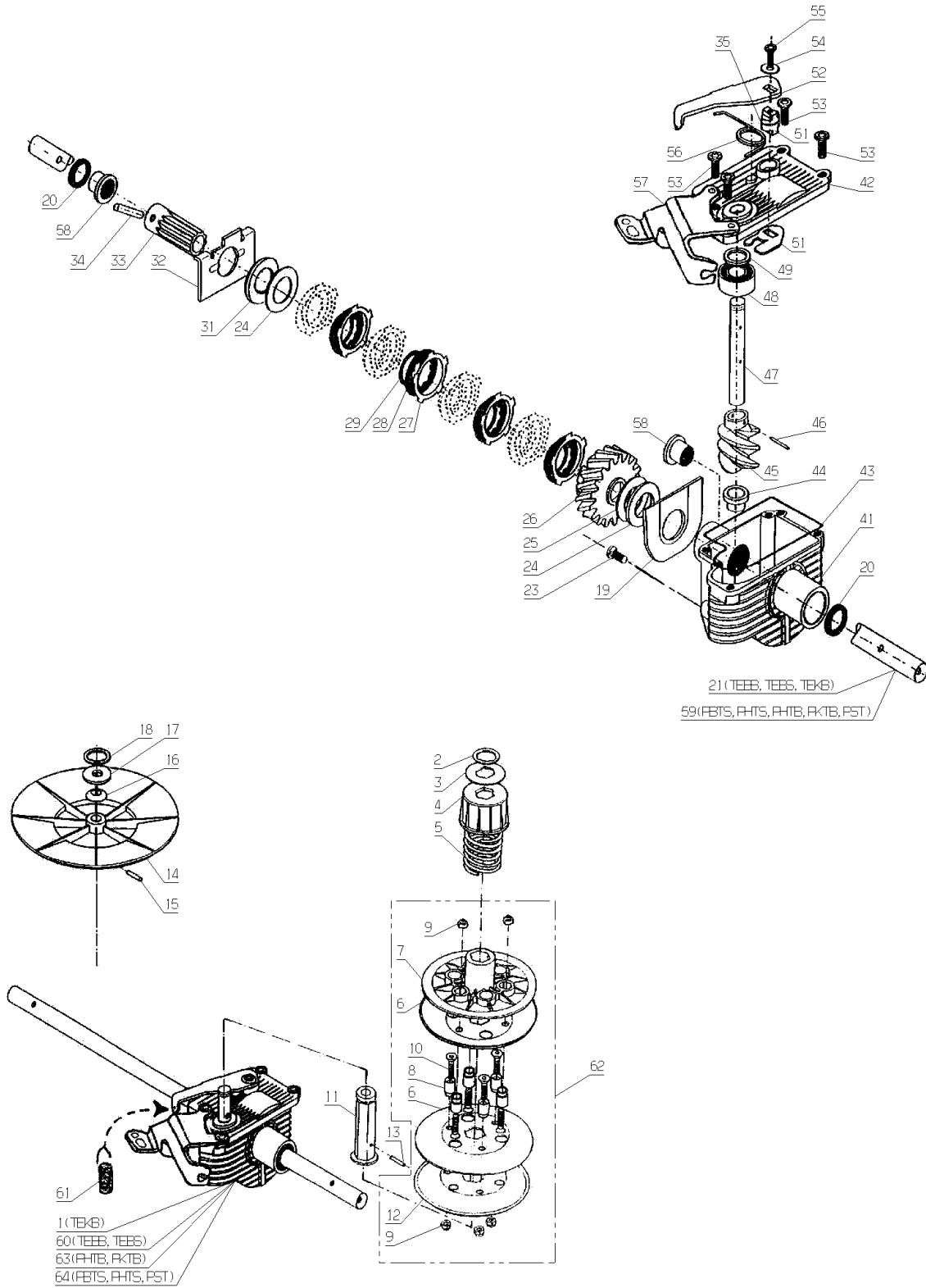

09/2005

Number	Part Number	Name	Quantity
1	71052	SPRING WASHER,DIN 1	1,000
2	3017	KEY 4X5	1,000
3	7035	FLAT WASHER	1,000
4	7341	FLAT WASHER 10,3X49	1,000
5	7342	BOLT 3/8 - 24	1,000
6	7357	-> 71031	1,000
7	22065	WASHER 25X8,5X3	1,000
8	23002	SHEAR WASHER	1,000
9	23604	INSULATION MUFF	1,000
10	23616	COUPLING 25 MM	1,000
11	24616	THERMAL COUPL.22,2	1,000
12	71067	HEXAG.SCREW HM8X75	1,000
13	71074	NUT HM8	1,000
14	71124	HEXAG.SCREW HM8X100	1,000
15	71127	KEY 4,8X6,5X15,72	1,000
16	PZ46E	BLADES FOR PRO 46CM	1,000



PBE - PSE  
PST

PL01131

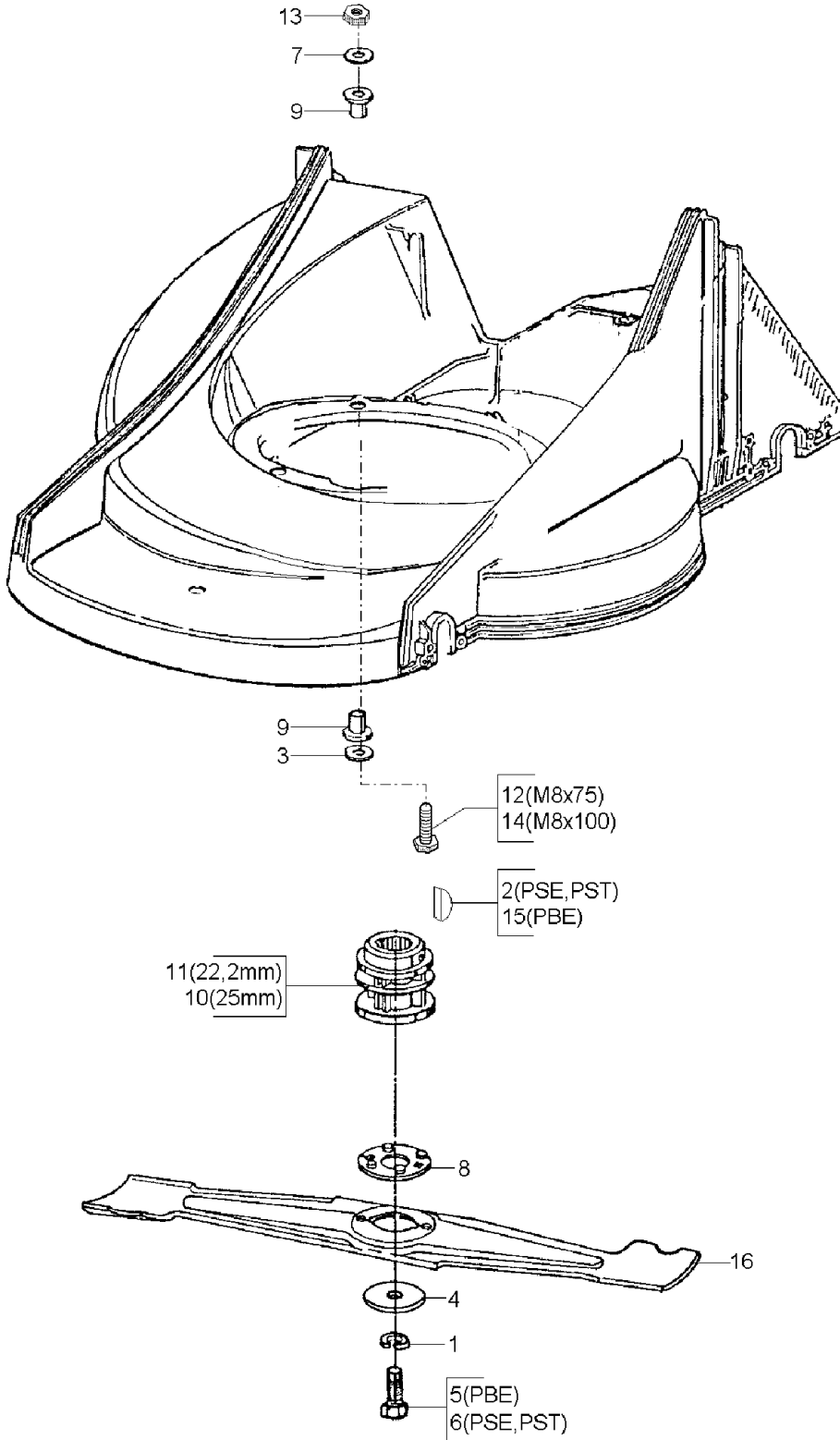

09/2006

Number	Part Number	Name	Quantity
1	23925	COLLECT.LOWER PU46E	1,000
2	23926	COLLECT.UPPER PU46E	1,000
3	23927	GREEN DUST GARD	1,000
4	23904	COLLECTOR HANDLE 46	1,000
5	24991	-> 2X 24903	1,000
6	71164	STARLOCK TRIM	1,000
7	7335	WASHER	1,000
8	7094	FLAT WASHER	1,000
9	23253	FAN HOUSING NG46	1,000
10	21204	RIVET TP 4X7,9	1,000
11	24906	FOAM PADDING	1,000
12	23928	INDICATOR FILLING G	1,000

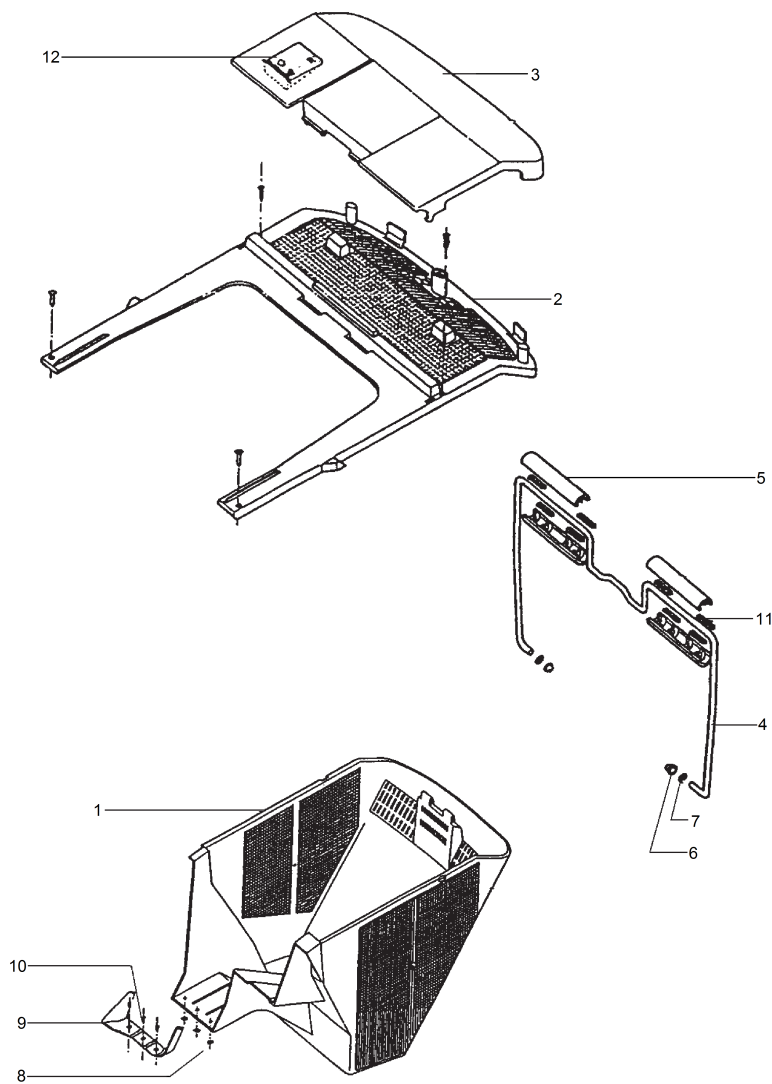

Number	Part Number	Name	Quantity
1	17001	CRANKCASE ASSY	1,000
2	17019	PIN	1,000
3	17049	HEXAG.SCREW HM6X30	1,000
4	17002	ENGINE SUPPORT	1,000
6	71151	NUT H 3/8-16UNC20	1,000
7	24607	PIN	1,000
8	24005	ENGINE WASHER	1,000
9	71074	NUT HM8	1,000

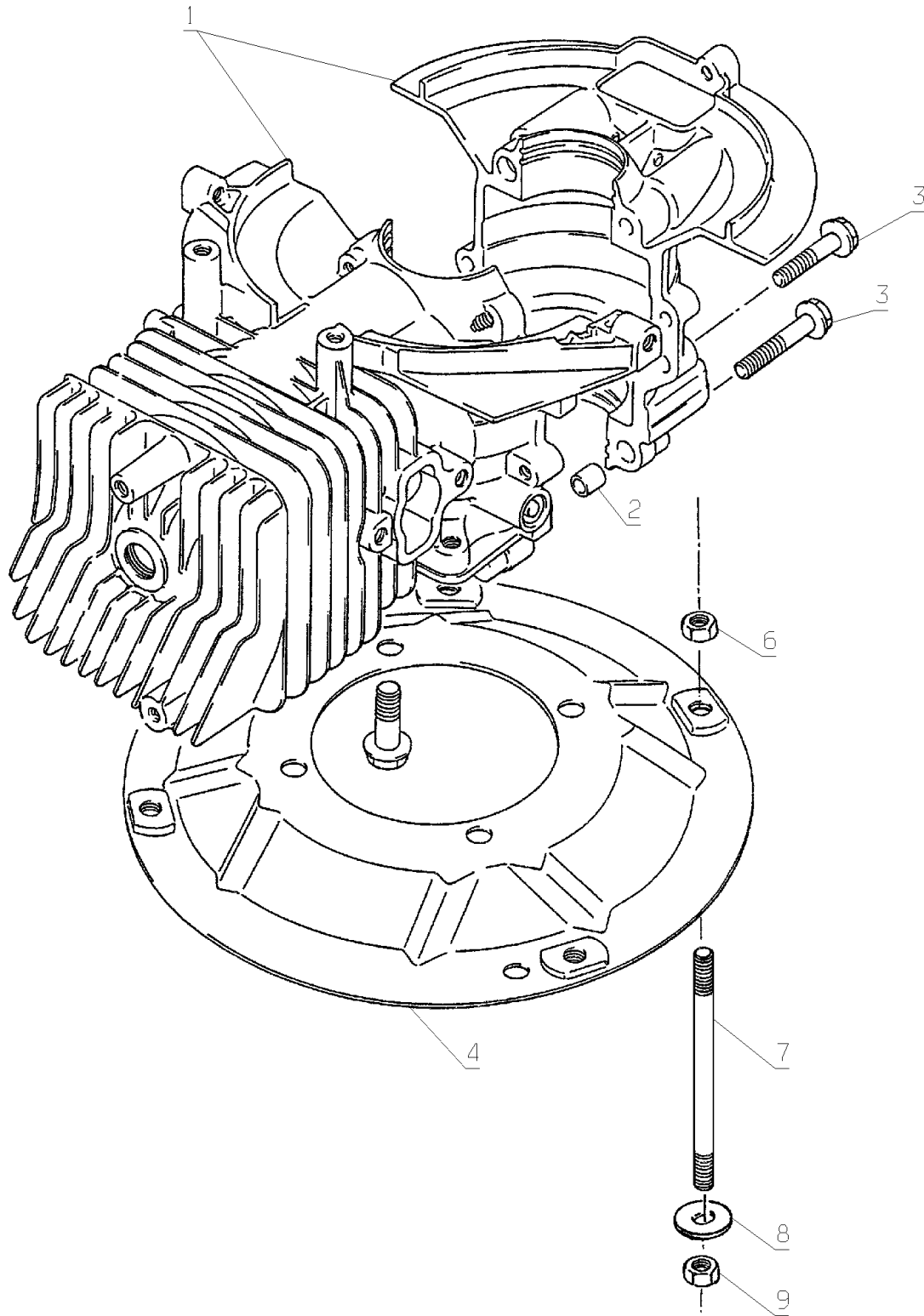

Number	Part Number	Name	Quantity
1	17003	PISTON D.58	1,000
2	17005	RING SET PISTON	1,000
3	17007	PIN PISTON	1,000
4	17008	BEARING	1,000
5	17009	CIRCLIP	1,000
6	17010	CRANKSHAFT ASSY	1,000
7	17051	BEARING UPPER	1,000
8	17069	BEARING LOWER	1,000
14	17016	THRUST WASHER UPPE	1,000
15	17017	OIL SEAL UPPER	1,000
16	17018	THRUST WASHER LOWE	1,000
17	17058	LOWER OIL SEAL	1,000
18	17020	REGULATOR ASSY	1,000
20	17021	SPACER GOVERNOR	1,000
23	17004	PISTON D.58,25	1,000
24	17006	RING SET PISTON	1,000
25	7337	KEY	1,000

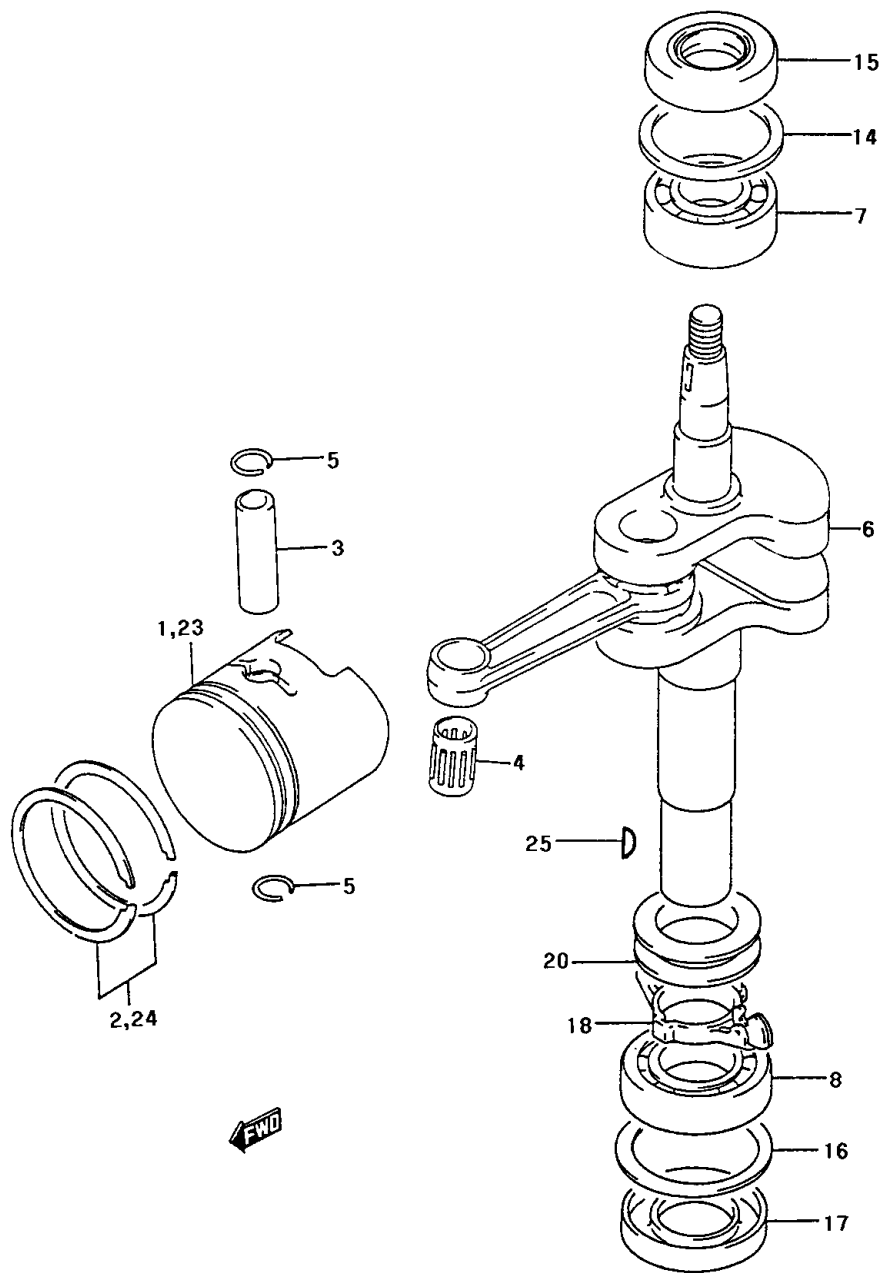

Number	Part Number	Name	Quantity
1	17022	GASKET CARBURETOR	1,000
2	15212	CARBURETOR GASKET	1,000
3	15108	GASKET AIR CLEANER	1,000
4	17023	SHIELD	1,000
5	17024	INSULATOR CARBURET.	1,000
6	17025	STUD BOLT M6X82	1,000
7	15104	NUT M6	1,000
8	17026	SHAFT THROTTLE RET.	1,000
9	17027	OIL SEAL	1,000
11	71029	WING NUT,DIN 315 M4	1,000
12	17030	REGULATOR LEVER	1,000
13	1557	NUT HM6	1,000
14	17031	ROD CARBURETOR	1,000
15	17032	SPRING	1,000
16	17033	BRACKET THROTTLE	1,000
17	17034	REGULATOR SPRING	1,000
18	15184	SCREW M6X20	1,000
19	17035	SPRING WASHER	1,000
21	15009	HEXAGON.SCREW M6X12	1,000
22	17037	CONTROL LEVER	1,000
23	2235	WASHER A6.4	1,000
24	17038	SPACER 6,1X10X9	1,000
26	2009	BOLT M5X16	1,000
27	17040	CHOKE LEVER	1,000
28	17041	SPACER	1,000
29	17042	SPRING	1,000
30	17043	ROD CHOKE	1,000



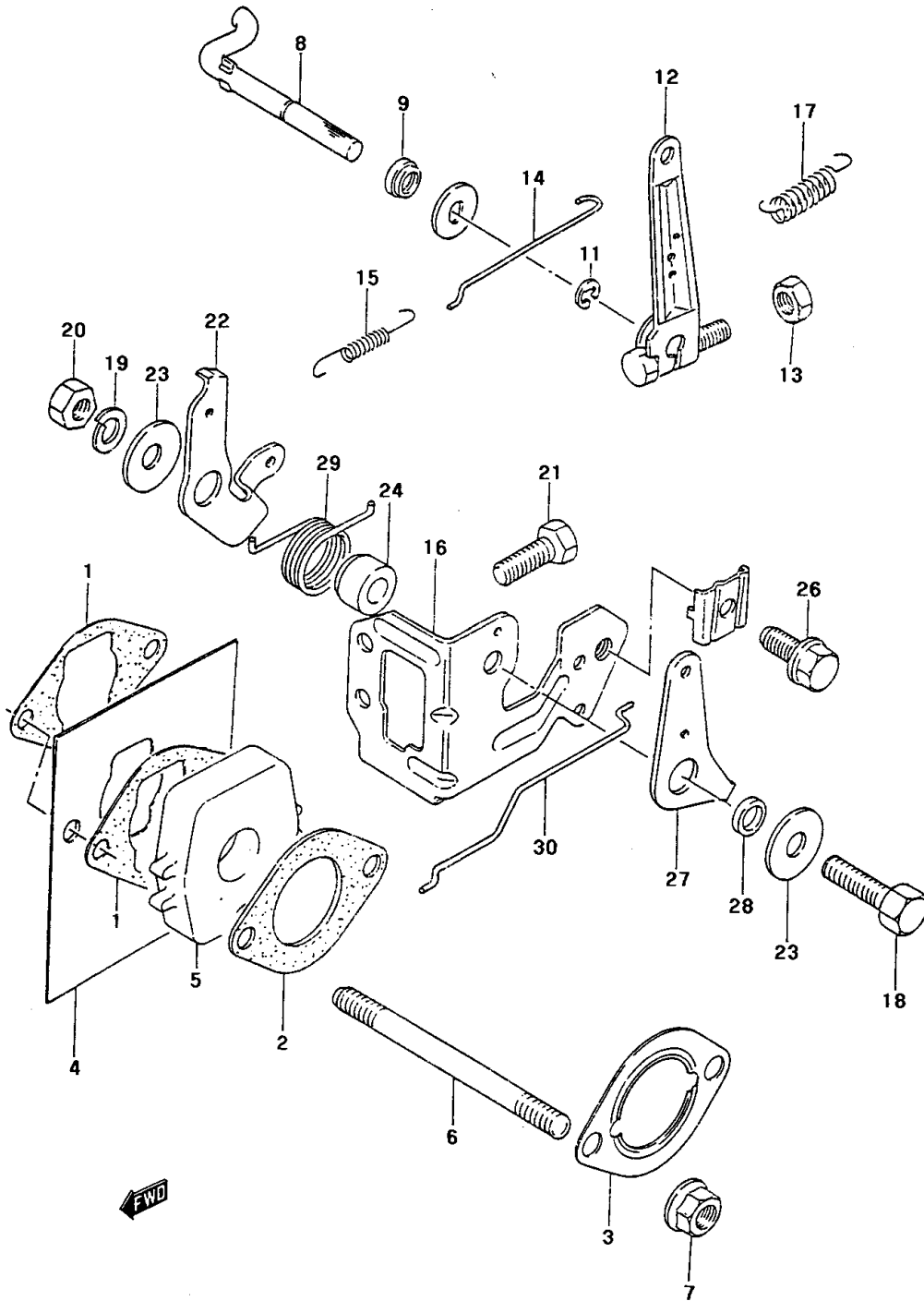

Number	Part Number	Name	Quantity
1	15083	FLOAT	1,000
2	15089	PIN	1,000
3	15086	SCREW	1,000
4	15082	GASKET FLOAT CHAMB.	1,000
5	15085	GASKET	1,000
6	17045	JET, PILOT (35)	1,000
7	17046	JET, MAIN (76,3)	1,000
8	15097	GASKET	1,000
9	15096	SCREW, DRAIN	1,000
10	17047	ADJUSTER	1,000
11	15095	SCREW	1,000
13	15090	NEEDLE VALVE	1,000
14	17048	NOZZLE	1,000
15	15084	RING	1,000
16	15100	CHAMBER FROAT	1,000
17	17044	CARBURETOR COMPLETE	1,000

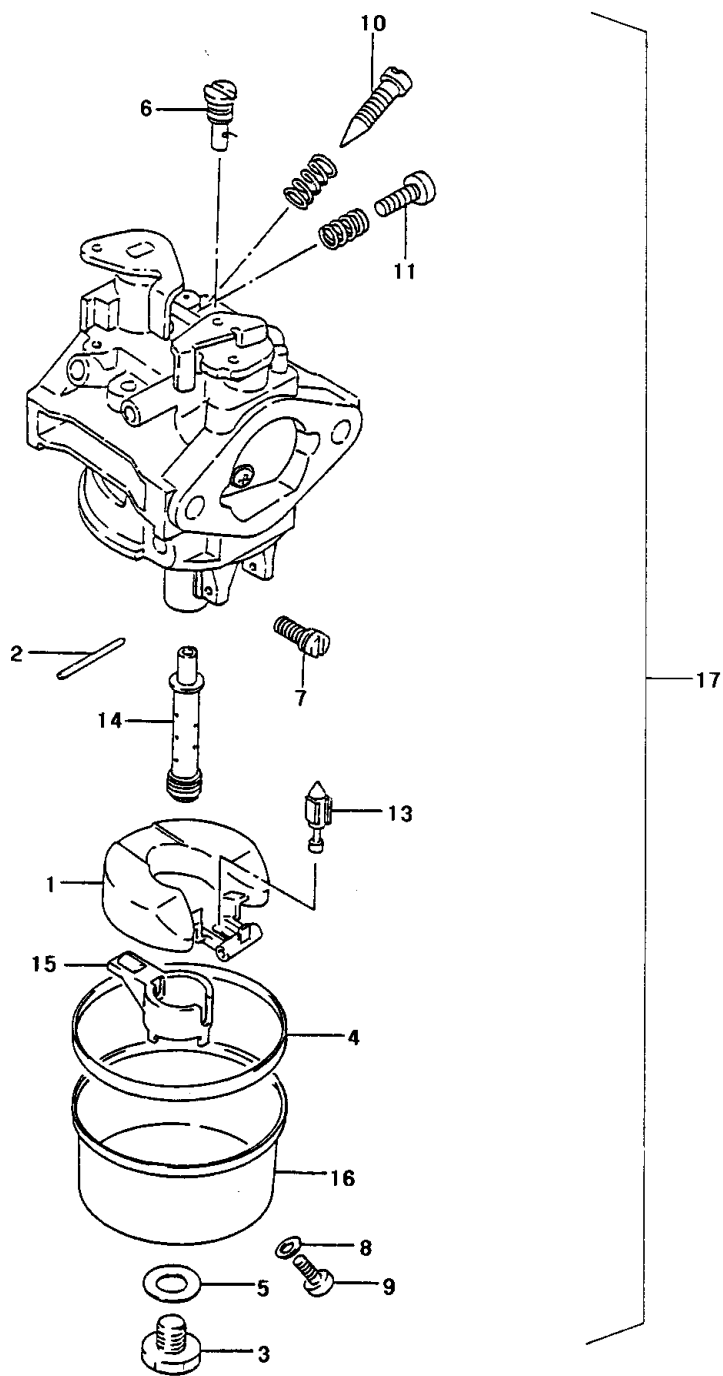

Number	Part Number	Name	Quantity
3	15108	GASKET AIR CLEANER	1,000
4	17054	SCREW	1,000
5	17067	WASHER MOD.92	1,000
6	17062	AIR CLEANER CPLT 92	1,000
7	17063	CLEANER MOD.92	1,000
8	17064	CLEANER COVER 92	1,000
11	17068	DEFLECTOR MOD.92	1,000

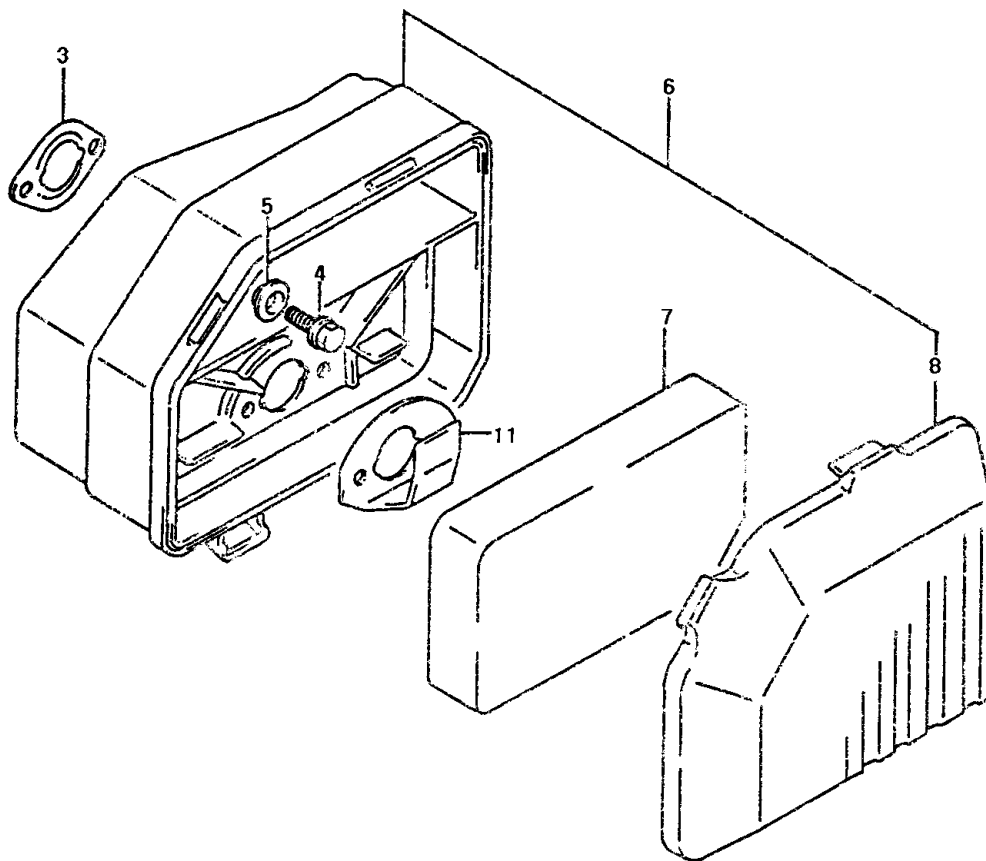

Number	Part Number	Name	Quantity
1	17055	GASKET	1,000
2	17070	MUFFLER	1,000
3	17071	STUD BOLT M8	1,000
4	17056	NUT M8	1,000
5	17061	SPRING WASHER	1,000
6	17072	COVER	1,000
7	71072	BOLT CHC M6X10	1,000
8	17073	HEXAG.SCREW M6X85	1,000
9	71075	WASHER	1,000

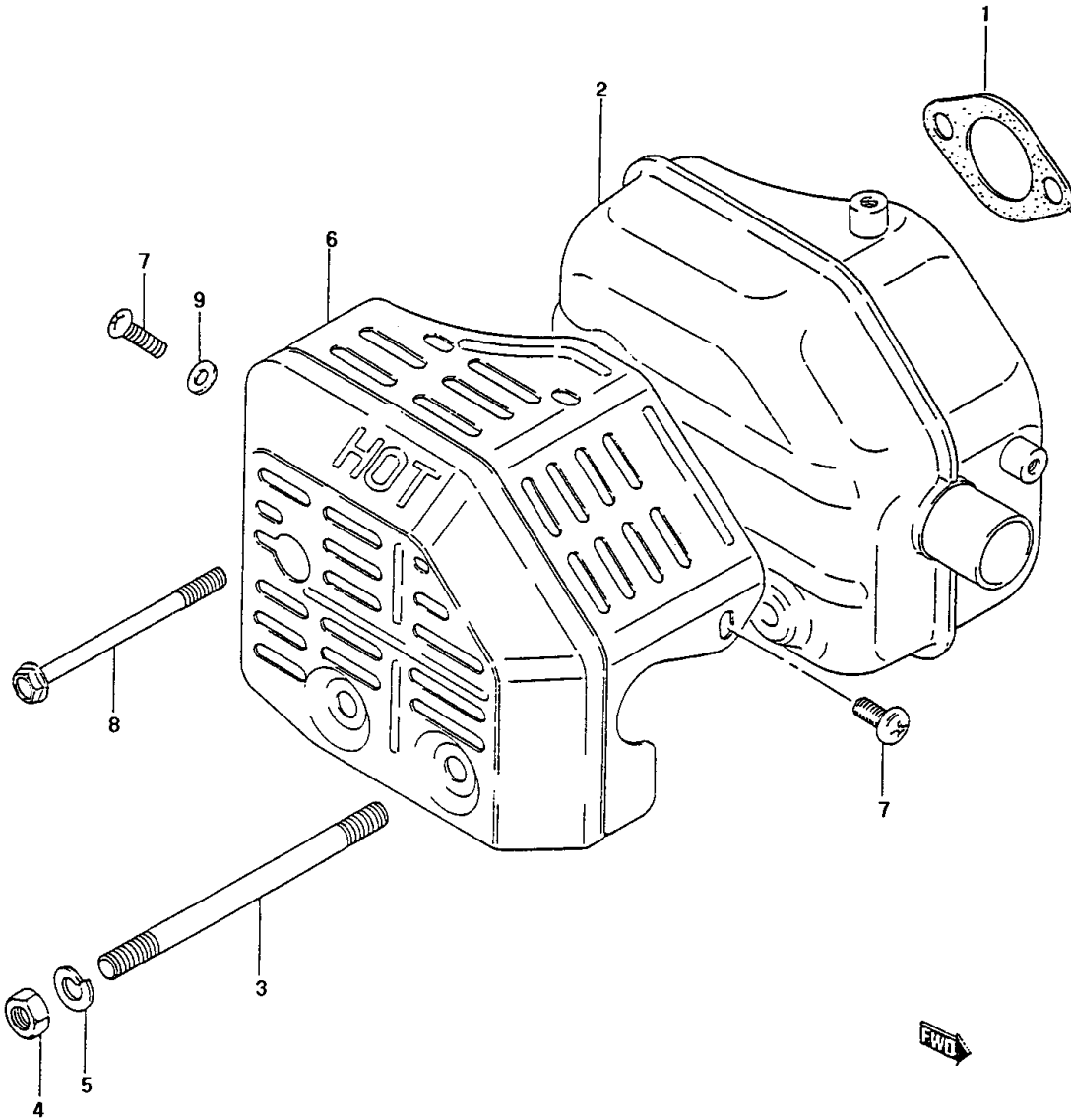

Number	Part Number	Name	Quantity
1	17075	COOLING FAN COVER	1,000
2	15009	HEXAGON.SCREW M6X12	1,000
3	17076	STARTER ASSY	1,000
4	17077	CASE	1,000
5	17078	SPRING KIT	1,000
6	17079	HOLDER	1,000
7	17080	PULLEY	1,000
8	17097	PAWL KIT	1,000
9	17093	DRIVE DISH	1,000
10	17081	GRIP	1,000
11	17096	ROPE D.4MM LG 2,5M	1,000
12	2059	HEXAGON.SCREW M6X10	1,000
13	17082	STARTER PULLEY	1,000
14	5334	-> 37997	1,000



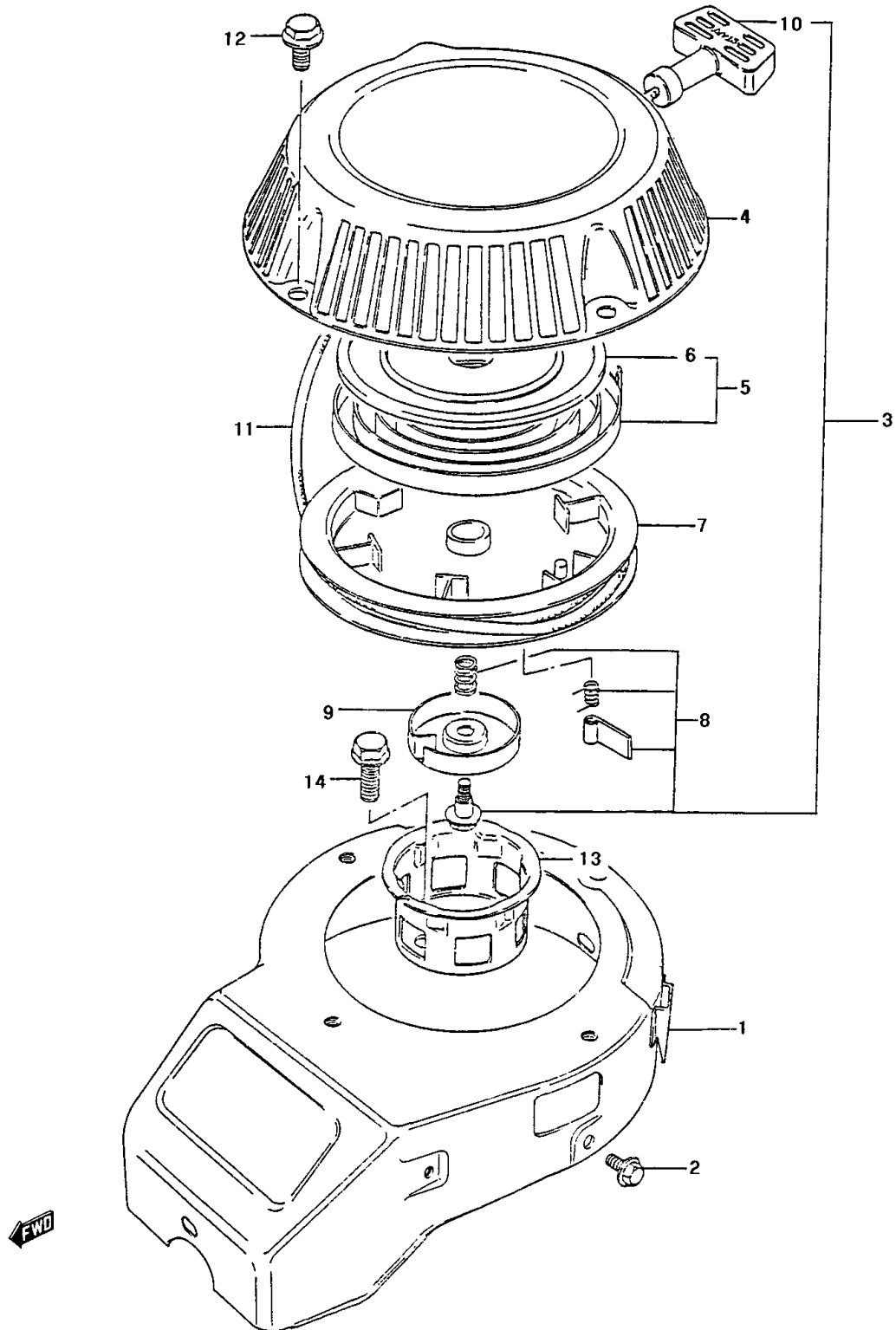

Number	Part Number	Name	Quantity
1	17083	KEY	1,000
2	17084	NUT M10	1,000
3	17085	FLYWHEEL	1,000
4	17086	COIL / TRANSISTER	1,000
5	17087	HEX.SCREW M6X20	1,000
7	7618	SAPRK PLUG SUPRES.	1,000
8	7619	SPARK PLUG D.14X9,5	1,000
10	15149	TERMINAL STOP SW.	1,000
11	15150	RIVET	1,000

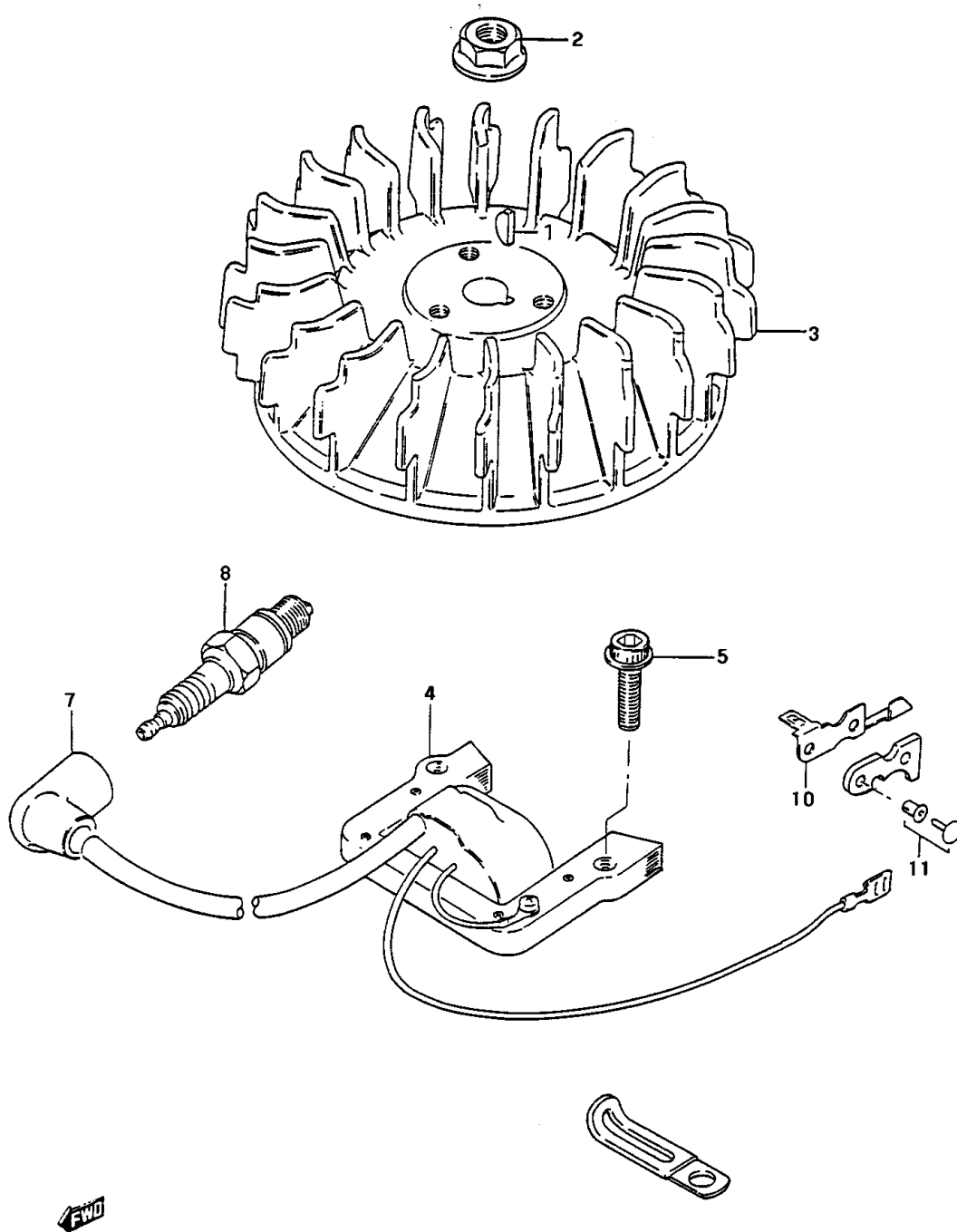

Number	Part Number	Name	Quantity
1	15245	BRAKE LEVER	1,000
4	15225	HEXAGON.SCREW M6X18	1,000
7	15251	SPRING	1,000

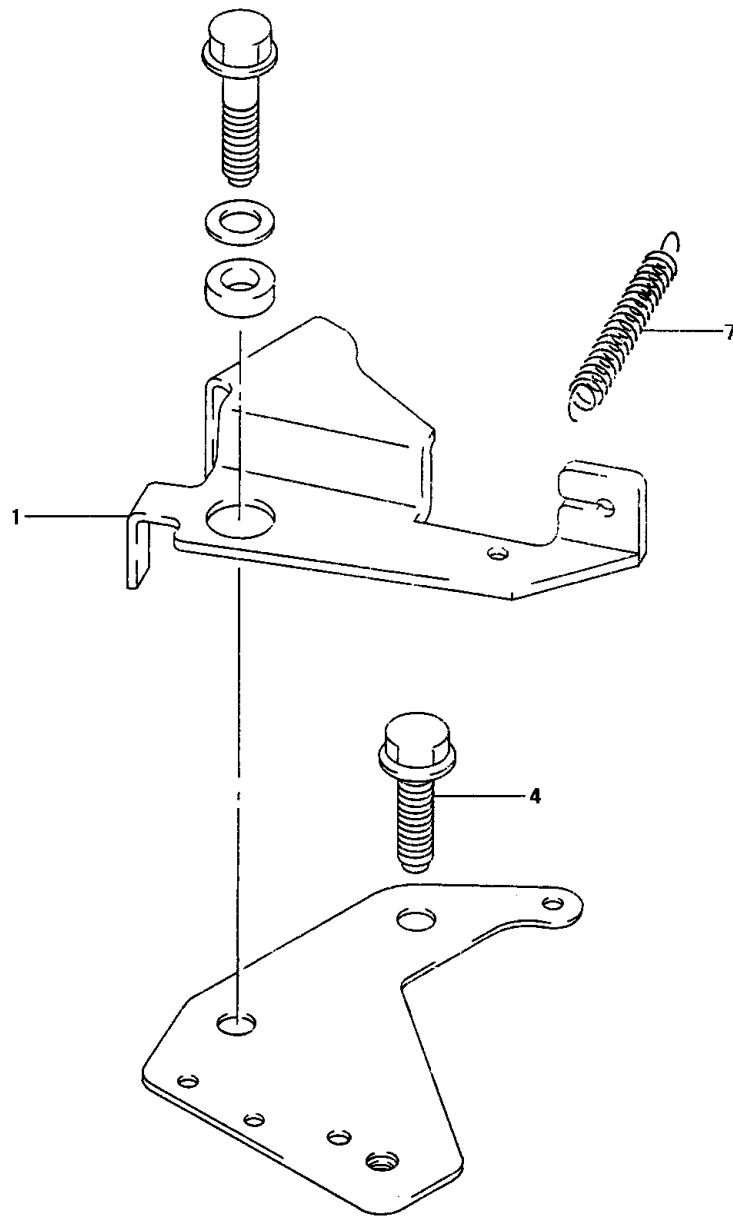

Number	Part Number	Name	Quantity
1	17091	TANK	1,000
2	15172	CAP ASSY	1,000
5	15175	CAP	1,000
7	1564	SCREW M6X12 4,5	1,000
8	15239	HOSE (TANK TO COCK)	1,000
9	15180	CLIP	1,000
10	15240	HOSE (TANK TO CARB)	1,000
12	17094	BRACKET	1,000

