

Number	Part Number	Name	Quantity
1	23810	46 CUT.DECK NM	1,000
2	23604	INSULATION MUFF	1,000
3	7035	FLAT WASHER	1,000
4	23615	CAP	1,000
5	24617	THERMAL PROTECTION	1,000
6	24005	ENGINE WASHER	1,000
7	9034	NYLON WASHER	1,000
8	5015	STUDED BUSH	1,000
9	23609	PULLEY DIA.46 NG46	1,000
10	5353	SCREW	1,000
11	24616	THERMAL COUPL.22,2	1,000
12	24618	COUPLING DISK	1,000
13	23002	SHEAR WASHER	1,000
14	PZ46E	BLADES FOR PRO 46CM	1,000
15	7341	FLAT WASHER 10,3X49	1,000
16	71052	SPRING WASHER,DIN 1	1,000
17	7342	BOLT 3/8 - 24	1,000
18	7046	SLEEVE	1,000
19	7047	SLEEVE	1,000
20	23275	REAR WHEEL KIT TR.	1,000
21	24087	PROTECTION WASHER	1,000
22	71072	BOLT CHC M6X10	1,000
23	5323	GEAR	1,000
24	24067	WASHER	1,000
25	71021	SCREW FHC/90 M6X12	1,000
26	5733	FREE WHEEL RIGHT	1,000
27	5734	FREE WHEEL LEFT	1,000
28	5329	CLICK SPRING	1,000
29	21609	PIN 5X22	1,000
30	43187	REAR WHEEL COVER TR	1,000
31	7330	WASHER	1,000
32	71016	WASHER 16X22X1	1,000
33	24692	SEALING WASHER	1,000
34	23340	CUTT.H.LEFT DISK RE	1,000
35	9022	BALL BEARING 6002	1,000
36	23025	INDEXED PLATE	1,000
37	5016	EXT. TRUARC RING	1,000
38	5067	WASHER BELLEVILLE	1,000
39	71070	SCREW 8X30	1,000
40	23070	FRONT LINKING SHAFT	1,000
41	23339	CUTT.H.RIGHT DISC R	1,000

Number	Part Number	Name	Quantity
42	23271	WHEEL ASSY 180GREEN	1,000
43	24669	ABSORBER SPRING	1,000
44	23062	SPACER DIA 12	1,000
45	71092	SCREW HM6-85,8.8	1,000
46	23730	PULLEY	1,000
47	23729	TAPERLOCK PULLEYD25	1,000
48	23636	COUPLING 22.2	1,000
49	23418	CUT.HEIGHT R+F LEFT	1,000
50	23419	CUT.HEIGHT R+F RIGH	1,000
51	24020	NOTCHED DISK	1,000
52	20021	WASHER 8,5X40X4	1,000
53	22031	SCREW 8X55	1,000
54	23004	SPACER BELT COVER	1,000
55	71074	NUT HM8	1,000
56	7335	WASHER	1,000
57	23605	BLACK COVER	1,000
58	71048	BOLT EJ.PT KA40X10	1,000
59	5019	GUIDE RING	1,000
60	7094	FLAT WASHER	1,000
61	21270	WASHER 6,4	1,000
62	21437	SCREW	1,000
63	6178	CLIP NUT	1,000
64	23303	TUBE + RAIL ASSY	1,000
65	23612	INSULATION	1,000
66	23041	RING	1,000
67	9071	SCREW M8X20	1,000
68	71076	NUT VERBUS HM8	1,000
69	5041	BOLT 8X30	1,000
70	5347	SCREW 8X25	1,000
71	71084	BOLT HM6X16 DIN 933	1,000
72	71201	NUT M6	1,000
73	24628	PROTECTING CAP HM6	1,000
74	23812	BELT COVER 46 WHITE	1,000
75	22065	WASHER 25X8,5X3	1,000
76	23414	DEFLECTOR GREEN CPL	1,000
77	23614	STRAP NG46 + ROD	1,000
78	23005	ROD	1,000
79	23607	DEFLECTOR QUARD 46	1,000
80	23712	WHITE INTERFACE 46	1,000
81	23631	BELT SPZ 837 MM	1,000
82	71135	SCREW 5X25	1,000

Number	Part Number	Name	Quantity
83	24647	SPRING	1,000
84	23075	SPRING SUPPORT	1,000
85	22029	FLAT WASHER 6,5	1,000
86	37561	NUT	1,000
87	23722	INSULATION MUFF	1,000
88	23620	COUPLING D25	1,000
89	23347	TAPERLOCK KIT D22.2	1,000
90	2235	WASHER A6.4	1,000
93	6187	SCREW	1,000
94	20564	WASHER 5,5	1,000
95	23626	DECK FLAP 46	1,000
96	24602	BASE PLATE BLACK	1,000
97	71206	BOLT EJ.PT KA50X16	1,000
98	23616	COUPLING 25 MM	1,000
105	23633	BELT 10X5/855LI	1,000
135	24058	SUPPORT VARIATOR	1,000
136	24085	SPACER PIVOT	1,000
137	24046	VARIATOR PIVOT	1,000
138	24836	RING	1,000
139	23632	PULLEY	1,000
140	24048	VARIATOR SPACER	1,000
144	21256	CIRCLIP	1,000
146	24659	GROOVE PULLEY	1,000
147	24846	SPACER 15X8X5,2	1,000
148	24045	PLATE SUPPORT	1,000
149	23279	DISC.GEARBOX46 ST	1,000
150	23278	DISC.GEARBOX 46 VAR	1,000

PBTS-PHTS
PHTB-PKTB-PST

191.01

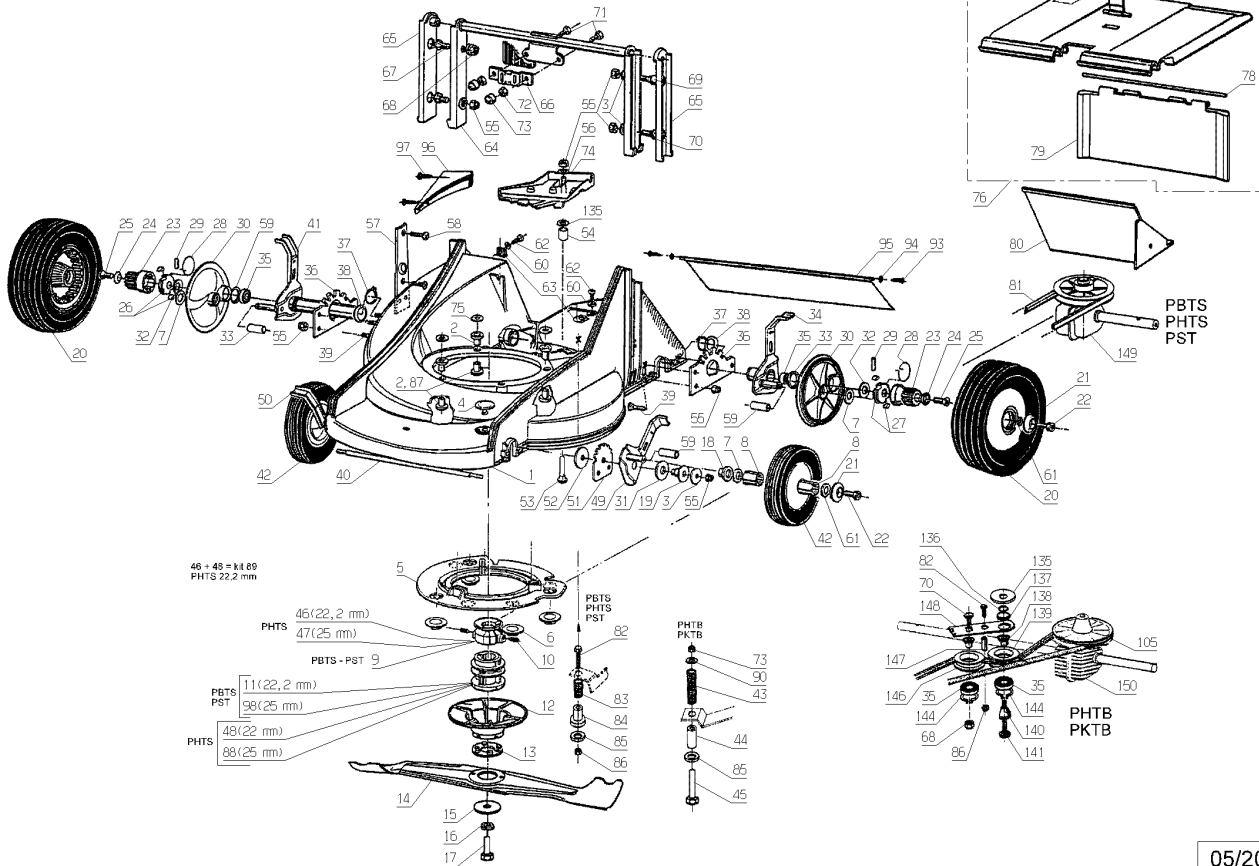

05/2006

Number	Part Number	Name	Quantity
1	23301	LOWER HANDLEBAR	1,000
2	23306	UP. HANDL. ASSY PSE	1,000
3	24014	COLLECTOR HOOK	1,000
4	23014	LOCKING PIN	1,000
5	24610	BUTTON (SMALL)	1,000
6	71074	NUT HM8	1,000
7	2217	BOLT TRCC 8X16	1,000
8	71060	BOLT TRCC 6X25	1,000
9	71201	NUT M6	1,000
10	2235	WASHER A6.4	1,000
11	23653	REMOTE CONTR.SLEEVE	1,000
12	24628	PROTECTING CAP HM6	1,000
13	24614	LOWER LOCKING JOINT	1,000
14	71028	BOLT TRCC 8X110	1,000
15	24629	UPPER LOCKING JOINT	1,000
16	21177	BALL M8	1,000
17	23361	LEVER + SCREWS	1,000
18	23675	THROTTLE CABL+SLEEVE	1,000
19	24683	HALF CAP	1,000
20	24682	COVER	1,000
21	71082	EJOT SCR.PT KA40X12	1,000
22	24433	BLADE EN-/DISENGAGE	1,000
23	24395	ENGINE SPEED MODUL	1,000
24	24050	SLEEVE STOP	1,000
25	71051	BOLT EJ.PT KA40X14	1,000
26	71050	BOLT EJ.PT KA40X14	1,000
27	23651	LOWER HOUSING	1,000
28	23666	CAPSULE	1,000
29	24434	DRIVE EN-/DISENGAGE	1,000
30	23650	CENTRAL HOUSING	1,000
31	24350	LEVER STOP	1,000
33	24690	LOCKING BUTTON	1,000
34	24609	SPRING	1,000
35	24059	BOLT	1,000
36	24684	TRUARC RING	1,000
37	23652	CENTR.HOUSING REAR	1,000
38	23660	DRIVE CABLE+SLEEVE	1,000
39	24778	SPRING	1,000
41	24128	HS MOTOR BRAKE DISK	1,000
42	23703	ENG.-BRAK.TRANS.B&S	1,000
43	23672	THROTTLE CABLE BRIG	1,000

Number	Part Number	Name	Quantity
44	23685	THROTTLECABLE GCV	1,000
50	24700	BUTTON	1,000
51	24670	GUIDE-RECOIL START.	1,000
60	24838	SPRING	1,000
61	24354	THROTTLE - SUZUKI	1,000
62	24672	THROTTLE CABLE PKTB	1,000
63	24701	INDEXED DISK	1,000
64	23053	THROTTLE R.PLATE	1,000
65	23723	BLADE CLUTCH CABLE	1,000
66	24758	LEVER SPRING	1,000
67	23700	MOTOR-BRAKE TRAN.	1,000
71	24703	BACK SPRING	1,000
72	24644	VARIATOR SLIDE	1,000
73	24702	LINKAGE	1,000
75	24845	LOCKING ARM	1,000
76	24843	DOUBLE CTRL.SPRING	1,000
77	24844	LOCKING LEVER	1,000
80	71237	SCREW F H M4-8,4.8	1,000
81	21525	NUT HM4	1,000
83	21524	SCREW M8X35	1,000
87	23681	CABLE+SLEEVE CLUTCH	1,000

PBTS-PHTS
PHTB-PKTB-PST

195.01

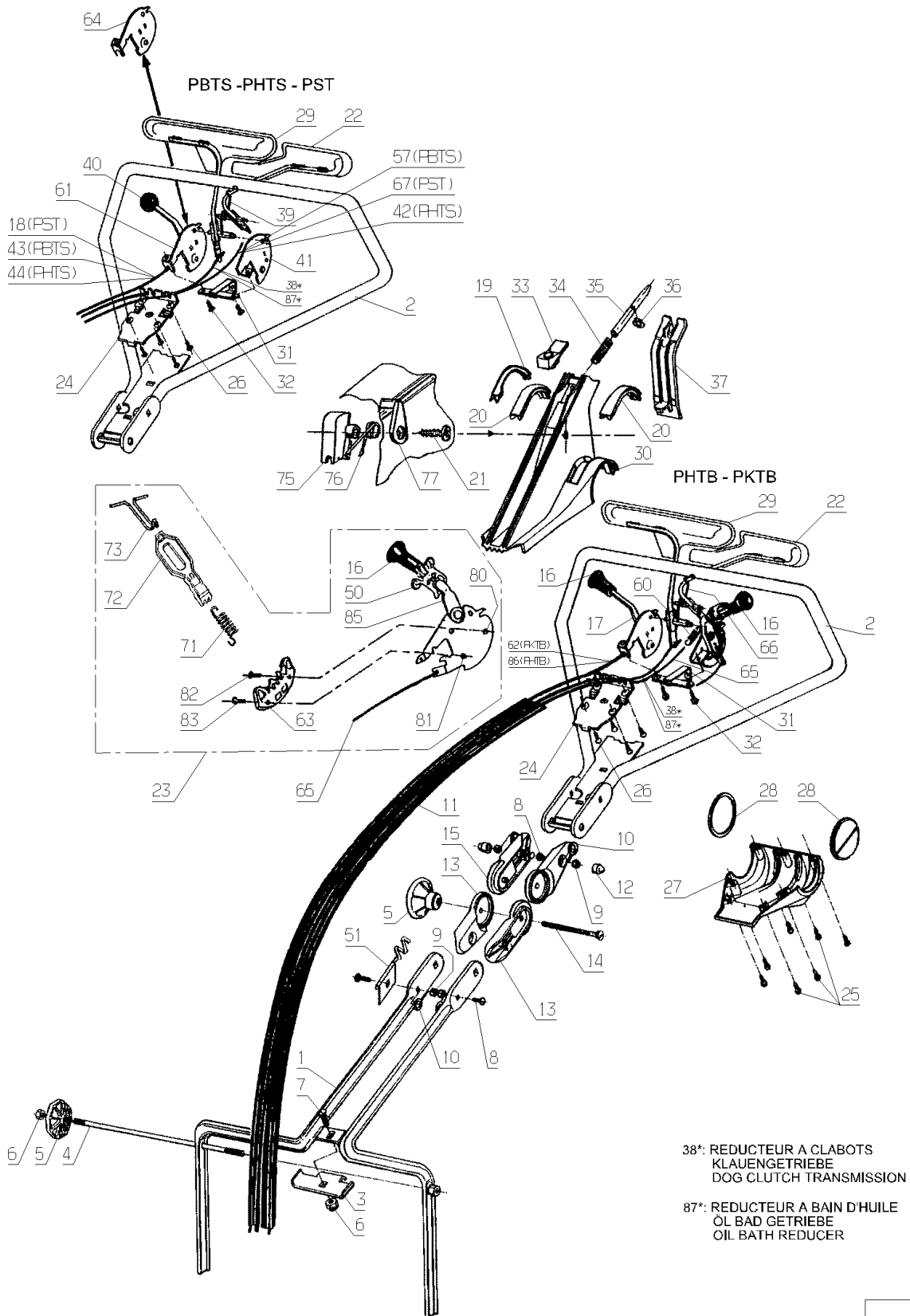

09/2006

Number	Part Number	Name	Quantity
1	23810	46 CUT.DECK NM	1,000
2	23604	INSULATION MUFF	1,000
3	7035	FLAT WASHER	1,000
4	23615	CAP	1,000
5	24617	THERMAL PROTECTION	1,000
6	24005	ENGINE WASHER	1,000
7	9034	NYLON WASHER	1,000
9	23609	PULLEY DIA.46 NG46	1,000
10	5353	SCREW	1,000
11	20537	WHEEL RING	1,000
12	24618	COUPLING DISK	1,000
13	23002	SHEAR WASHER	1,000
14	PZ46E	BLADES FOR PRO 46CM	1,000
15	7341	FLAT WASHER 10,3X49	1,000
16	71052	SPRING WASHER,DIN 1	1,000
17	7342	BOLT 3/8 - 24	1,000
19	7047	SLEEVE	1,000
20	23275	REAR WHEEL KIT TR.	1,000
21	24087	PROTECTION WASHER	1,000
22	71072	BOLT CHC M6X10	1,000
23	5323	GEAR	1,000
24	24067	WASHER	1,000
25	71021	SCREW FHC/90 M6X12	1,000
26	5733	FREE WHEEL RIGHT	1,000
27	5734	FREE WHEEL LEFT	1,000
28	5329	CLICK SPRING	1,000
29	21609	PIN 5X22	1,000
30	43187	REAR WHEEL COVER TR	1,000
31	7330	WASHER	1,000
32	71016	WASHER 16X22X1	1,000
33	24692	SEALING WASHER	1,000
34	23340	CUTT.H.LEFT DISK RE	1,000
35	9022	BALL BEARING 6002	1,000
36	23025	INDEXED PLATE	1,000
37	5016	EXT. TRUARC RING	1,000
38	5067	WASHER BELLEVILLE	1,000
39	71070	SCREW 8X30	1,000
40	23070	FRONT LINKING SHAFT	1,000
41	23339	CUTT.H.RIGHT DISC R	1,000
43	24669	ABSORBER SPRING	1,000
44	23062	SPACER DIA 12	1,000

Number	Part Number	Name	Quantity
45	71092	SCREW HM6-85,8.8	1,000
46	20536	CRINKLE WASHER	1,000
47	23729	TAPERLOCK PULLEYD25	1,000
48	6011	WASHER 12,2X23,2X1	1,000
49	23422	CUT.HEIGHT LEFT	1,000
50	23423	CUT.HEIGHT RIGHT	1,000
51	24020	NOTCHED DISK	1,000
52	20021	WASHER 8,5X40X4	1,000
53	22031	SCREW 8X55	1,000
54	23004	SPACER BELT COVER	1,000
55	71074	NUT HM8	1,000
56	7335	WASHER	1,000
57	23605	BLACK COVER	1,000
58	71048	BOLT EJ.PT KA40X10	1,000
59	5019	GUIDE RING	1,000
60	7094	FLAT WASHER	1,000
61	21270	WASHER 6,4	1,000
62	21437	SCREW	1,000
63	6178	CLIP NUT	1,000
64	24810	WHEEL 180 + BEARING	1,000
65	24132	SHAFT WASHER	1,000
66	71222	SCREW FHC/90 6X12	1,000
67	23278	DISC.GEARBOX 46 VAR	1,000
68	71076	NUT VERBUS HM8	1,000
69	24045	PLATE SUPPORT	1,000
70	5347	SCREW 8X25	1,000
71	24922	WHEEL FLASK 180 GR.	1,000
72	23279	DISC.GEARBOX46 ST	1,000
73	24628	PROTECTING CAP HM6	1,000
74	23812	BELT COVER 46 WHITE	1,000
75	22065	WASHER 25X8,5X3	1,000
76	23414	DEFLECTOR GREEN CPL	1,000
77	23614	STRAP NG46 + ROD	1,000
78	23005	ROD	1,000
79	23607	DEFLECTOR QUARD 46	1,000
80	23712	WHITE INTERFACE 46	1,000
81	23631	BELT SPZ 837 MM	1,000
82	71135	SCREW 5X25	1,000
83	24647	SPRING	1,000
84	23075	SPRING SUPPORT	1,000
85	22029	FLAT WASHER 6,5	1,000

Number	Part Number	Name	Quantity
86	37561	NUT	1,000
87	23722	INSULATION MUFF	1,000
88	23620	COUPLING D25	1,000
89	36467	COUPLING DIA.25	1,000
90	2235	WASHER A6.4	1,000
93	6187	SCREW	1,000
94	20564	WASHER 5,5	1,000
95	23626	DECK FLAP 46	1,000
96	24602	BASE PLATE BLACK	1,000
97	71206	BOLT EJ.PT KA50X16	1,000
98	20533	BEARING DIAM.12	1,000
105	23633	BELT 10X5/855LI	1,000
135	24058	SUPPORT VARIATOR	1,000
136	24085	SPACER PIVOT	1,000
137	24046	VARIATOR PIVOT	1,000
138	24836	RING	1,000
139	23632	PULLEY	1,000
140	24048	VARIATOR SPACER	1,000
144	21256	CIRCLIP	1,000
146	24659	GROOVE PULLEY	1,000
147	24846	SPACER 15X8X5,2	1,000

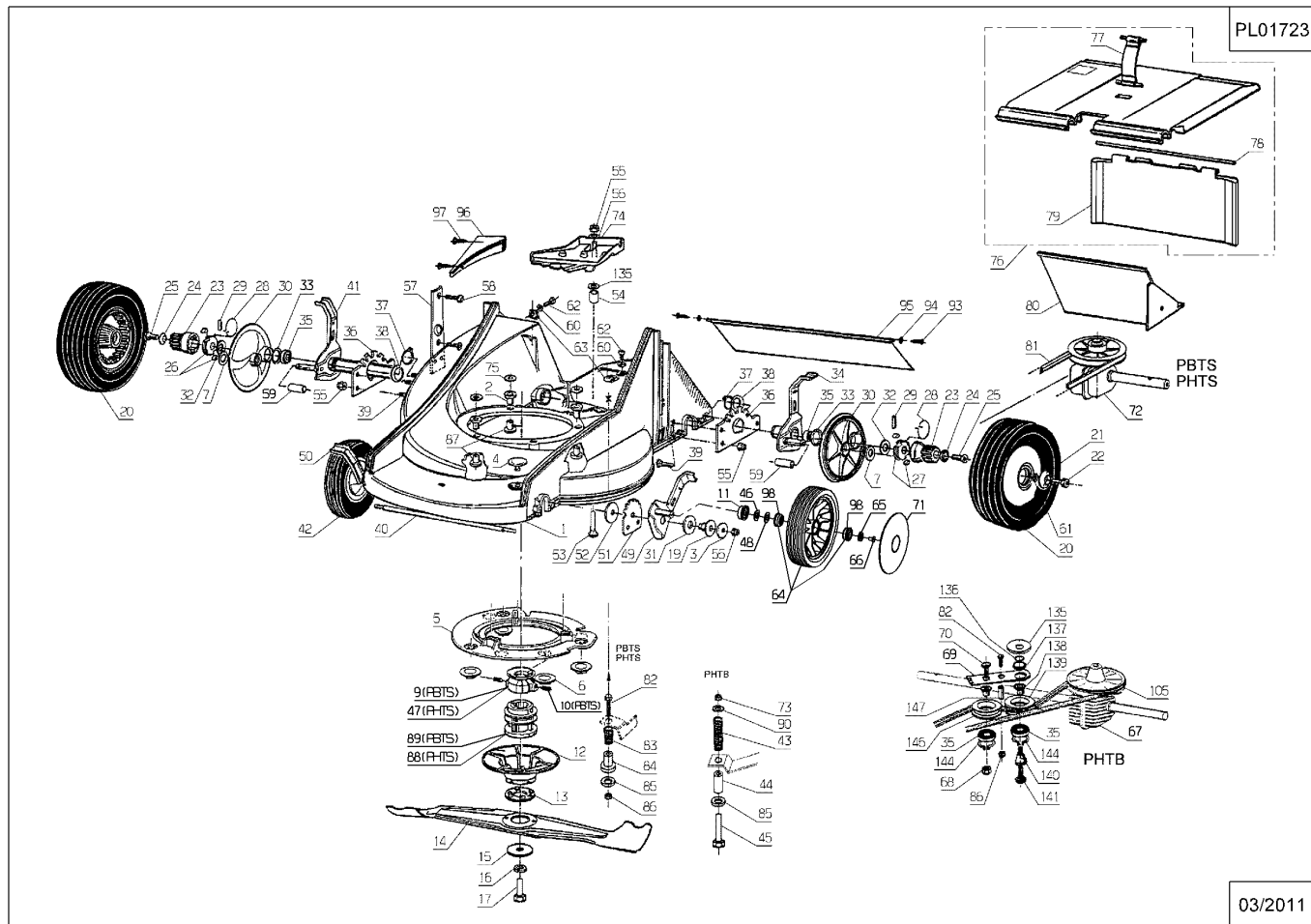

03/2011

Number	Part Number	Name	Quantity
1	71201	NUT M6	1,000
2	21585	SCREW BZ 4,2X9,5	1,000
3	22029	FLAT WASHER 6,5	1,000
4	32351	DRIVE CABLE	1,000
5	35571	ENGINE BRAK.CABL.H.	1,000
6	36839	RIGHT BRACKET	1,000
7	36903	LEVER	1,000
8	36904	LEVER	1,000
9	37027	THROTTLE CABLE	1,000
10	37067	BOTTOM	1,000
11	37173	STOP	1,000
12	37342	LEVER	1,000
13	37343	RUBBER PROTECTION	1,000
14	37344	RUBBER PROTECTION	1,000
15	37611	COVER	1,000
16	37347	HANDLE BAR	1,000
17	43063	THROTTLE LEVER GUID	1,000
18	43065	SPRING	1,000
19	43089	COVER	1,000
20	71023	SCREW HM 6X50	1,000
21	71279	SCREW B.42-13 4.6	1,000
22	71308	LOCK NUT M5	1,000
23	71409	SCREW FHC/90 M5-30	1,000

PHTS

PL01465

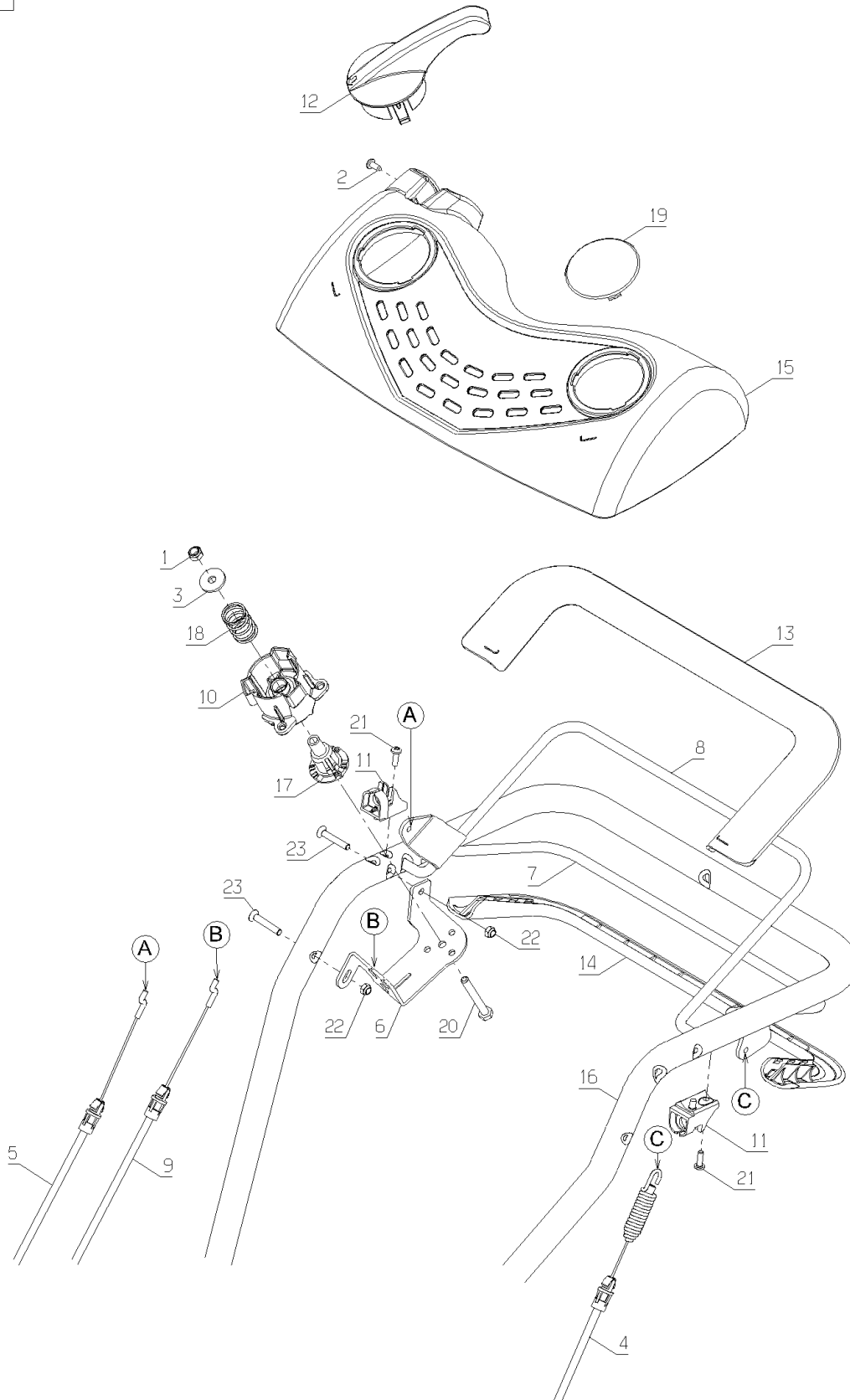

06/2009

Number	Part Number	Name	Quantity
1	71205	SCREW M8	1,000
2	5347	SCREW 8X25	1,000
3	6416	WASHER	1,000
4	7035	FLAT WASHER	1,000
5	7335	WASHER	1,000
6	9071	SCREW M8X20	1,000
7	23014	LOCKING PIN	1,000
8	23612	INSULATION	1,000
9	24610	BUTTON (SMALL)	1,000
10	35567	STRAP	1,000
11	36432	HOOK	1,000
12	36084	TUBE + GUIDE	1,000
13	37089	SCREW	1,000
14	37347	HANDLE BAR	1,000
15	37348	HANDLE BAR	1,000
16	37530	STOP	1,000
17	41437	CAP 22X2,5	1,000
18	42088	O-RING 18X8	1,000
19	42092	BUSH	1,000
20	71074	NUT HM8	1,000
21	71076	NUT VERBUS HM8	1,000

PL01468

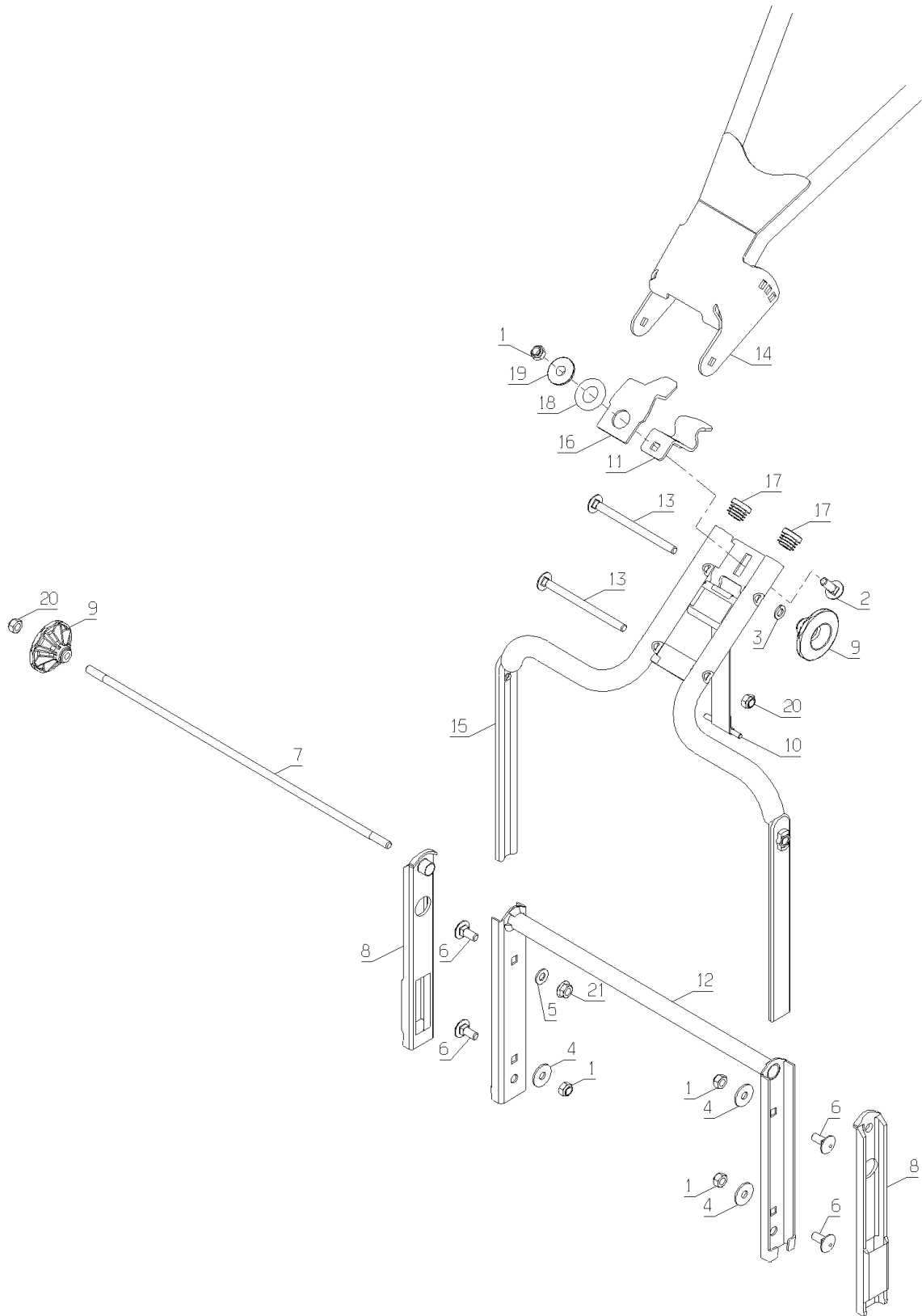

01/2009

Number	Part Number	Name	Quantity
1	42240	OIL BATH VAR. REDUC	1,000
2	71019	CIRCLIP 16X1	1,000
3	24072	WASHER 32X16,5X1	1,000
4	24649	PULLEY STOP	1,000
5	24651	PULLEY SPRING	1,000
6	24044	1/2 PULLEY FLANGE	1,000
7	24665	1/2 PULLEY	1,000
8	24069	GUIDE STUB	1,000
9	37561	NUT	1,000
10	71022	SCREW FHC/90 M5X20	1,000
11	41823	WASHER+AXLE PUL.CPL	1,000
12	24840	1/2 PULLEY	1,000
13	20556	PIN 3X15	1,000
14	22455	REDUCTION GEAR PULL	1,000
15	71088	PIN 3X22	1,000
16	20561	CURLED WASHER A10	1,000
17	21036	FLAT WASHER 10.5	1,000
18	20559	CIRCLIPS 10	1,000
19	41105	CASING REINFORCEMENT	1,000
20	71219	LIP SEAL 15X21X5	1,000
21	24135	SLOW SHAFT NG51 RD	1,000
23	71211	BOLT EJ-PT 50X16	1,000
24	41102	STRIDDED STOP	1,000
25	71216	STOP WASHER	1,000
26	24776	BELL + WHEEL SET	1,000
27	41097	EXT.CLUTCH PLATE	1,000
28	41096	INT.CLUTCH PLATE	1,000
29	71214	WASHER R9	1,000
31	41095	STOP WASHER	1,000
32	41094	FORK RD	1,000
33	41104	CARRIER	1,000
34	21609	PIN 5X22	1,000
35	71220	O-RING 8,9X1,9	1,000
41	41050	-> 41052 + 42095	1,000
42	41051	REDUCT. GEAR COVER	1,000
43	41110	COVER SEAL	1,000
44	20558	RING C/10 15X10	1,000
45	20555	ENDLESS BOLT	1,000
47	41055	QUICK SHAFT N.M	1,000
48	24642	BEARING	1,000
49	71218	LIP SEAL 10X18X4	1,000

Number	Part Number	Name	Quantity
51	41822	PUSH AXLE (SET)	1,000
52	41059	CONTROL ARM	1,000
53	71244	BOLT EJ-PT 50X20	1,000
54	7094	FLAT WASHER	1,000
55	71213	BOLT M4X10	1,000
56	41060	CLUTCH SPRING	1,000
57	42095	BRACKET	1,000
58	41056	SELF LUBRICATE BUSH	1,000
59	23087	SLOW SHAFT 46 RD	1,000
60	24269	OIL BATH RED 1SPEED	1,000
61	24686	SPRING	1,000
62	24275	VARIATOR PULLEY	1,000
63	23278	DISC.GEARBOX 46 VAR	1,000
64	23279	DISC.GEARBOX46 ST	1,000

VIVA 46/51

180.01

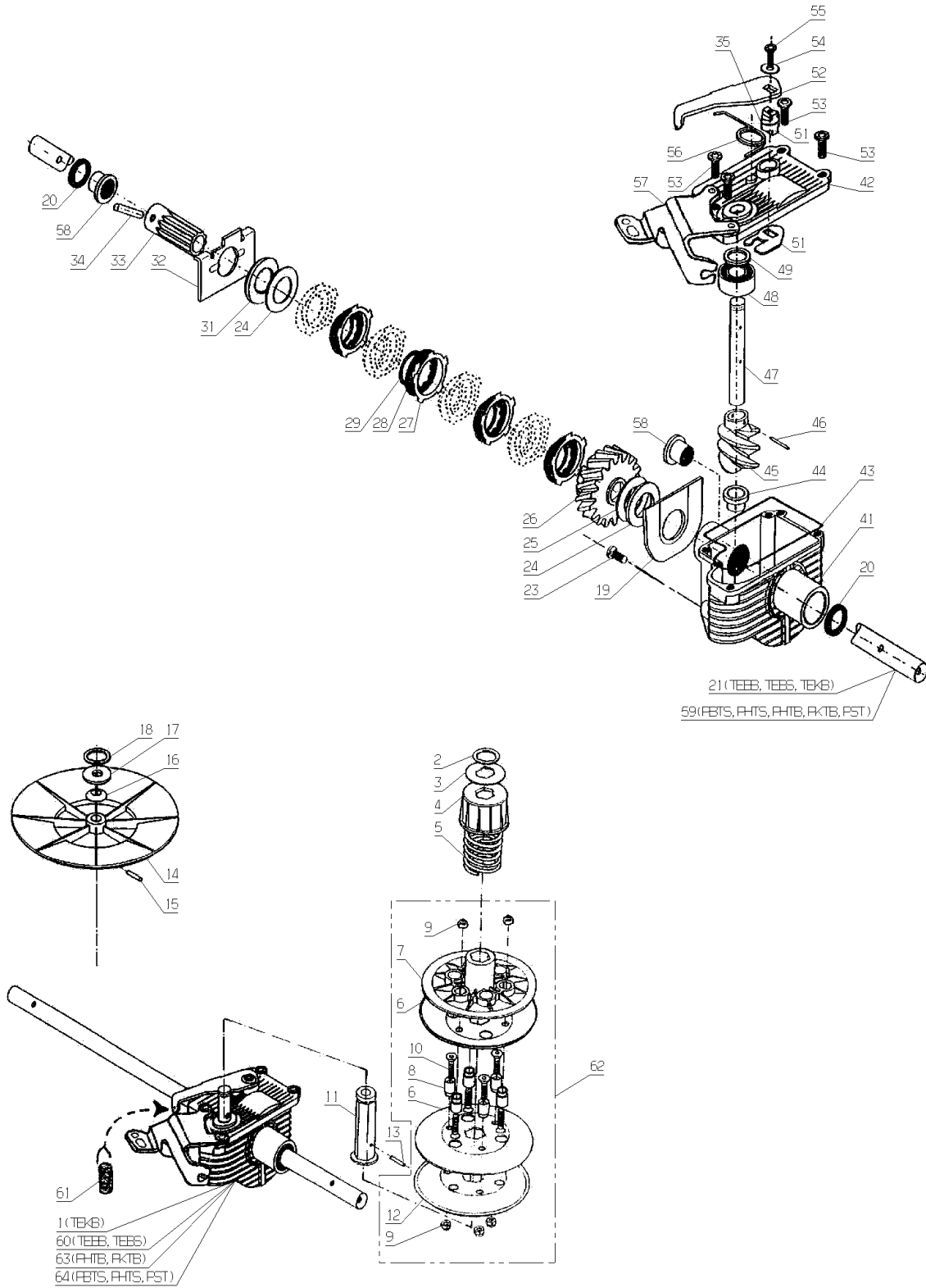

09/2005

Number	Part Number	Name	Quantity
1	2217	BOLT TRCC 8X16	1,000
2	71052	SPRING WASHER,DIN 1	1,000
3	5353	SCREW	1,000
4	7035	FLAT WASHER	1,000
5	7341	FLAT WASHER 10,3X49	1,000
6	7342	BOLT 3/8 - 24	1,000
7	22029	FLAT WASHER 6,5	1,000
8	22065	WASHER 25X8,5X3	1,000
9	23002	SHEAR WASHER	1,000
11	23604	INSULATION MUFF	1,000
12	23609	PULLEY DIA.46 NG46	1,000
13	23616	COUPLING 25 MM	1,000
14	23620	COUPLING D25	1,000
15	23636	COUPLING 22.2	1,000
16	23729	TAPERLOCK PULLEYD25	1,000
17	23730	PULLEY	1,000
18	24005	ENGINE WASHER	1,000
19	24616	THERMAL COUPL.22,2	1,000
20	24617	THERMAL PROTECTION	1,000
21	24618	COUPLING DISK	1,000
22	24626	THERM.PROTECT.4 H.	1,000
23	41427	STUD M10/M8X77	1,000
24	71067	HEXAG.SCREW HM8X75	1,000
25	71074	NUT HM8	1,000
26	71124	HEXAG.SCREW HM8X100	1,000
27	PZ46E	BLADES FOR PRO 46CM	1,000
28	7337	KEY	1,000

PBTS - PHE
PHTS

PL01130

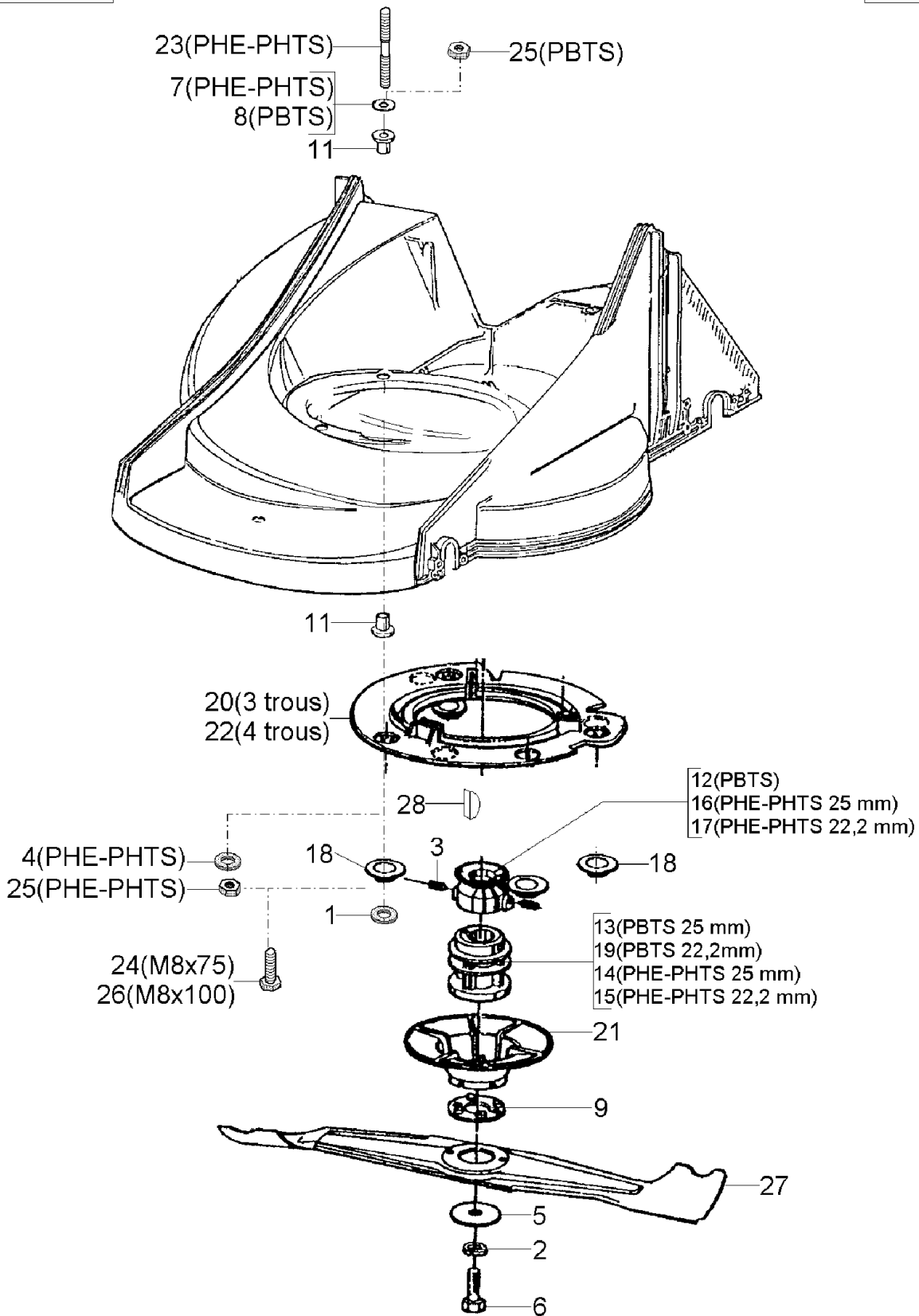

09/2006

Number	Part Number	Name	Quantity
1	23925	COLLECT.LOWER PU46E	1,000
2	23926	COLLECT.UPPER PU46E	1,000
3	23927	GREEN DUST GARD	1,000
4	23904	COLLECTOR HANDLE 46	1,000
5	24991	-> 2X 24903	1,000
6	71164	STARLOCK TRIM	1,000
7	7335	WASHER	1,000
8	7094	FLAT WASHER	1,000
9	23253	FAN HOUSING NG46	1,000
10	21204	RIVET TP 4X7,9	1,000
11	24906	FOAM PADDING	1,000
12	23928	INDICATOR FILLING G	1,000

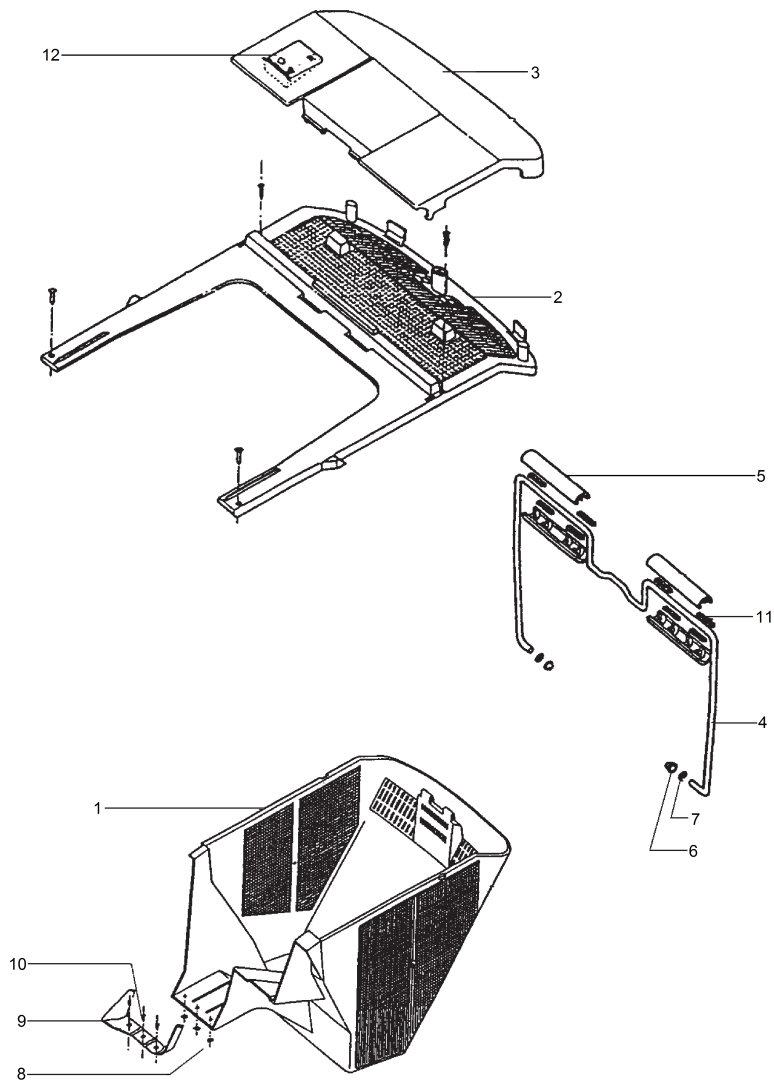

Number	Part Number	Name	Quantity
1	18500	CRANKCASE 160	1,000
2	18507	COLLAR	1,000
3	18502	CIRCLIP	1,000
4	18504	COVER	1,000
5	18506	SCREW 6X14	1,000
6	18503	CASE ROCKER	1,000
7	18505	SCREW 6X12	1,000
8	3861	SPARK PLUG D.14X19R	1,000
9	18516	SLINGER OIL	1,000
10	18523	WASHER 6MM	1,000
11	18520	PIVOT	1,000
12	18517	FEEDER	1,000
13	18518	SLINGER OIL	1,000
14	18524	CIRCLIPS	1,000
15	18519	COTTER PIN	1,000
16	18515	REGULATOR SHAFT	1,000
17	18528	CUP	1,000
18	18527	WASHER 6MM	1,000
19	18521	GOVERNOR SHAFT	1,000
20	18529	SLEEVE	1,000
21	18511	OIL GAUGE	1,000
22	18512	SEAL	1,000
23	18513	FILLING TUBE	1,000
24	18514	WASHER	1,000
25	18526	O-RING	1,000
26	18510	OILSUMP	1,000
28	18522	SCREW 6X25	1,000
29	18525	OIL SEAL	1,000

HONDA
OHC 160

261.01

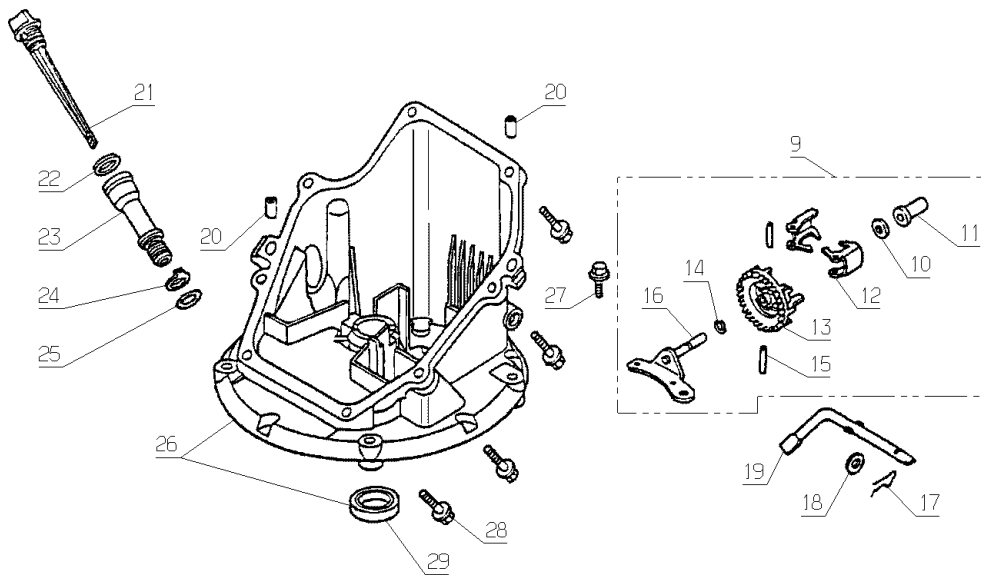
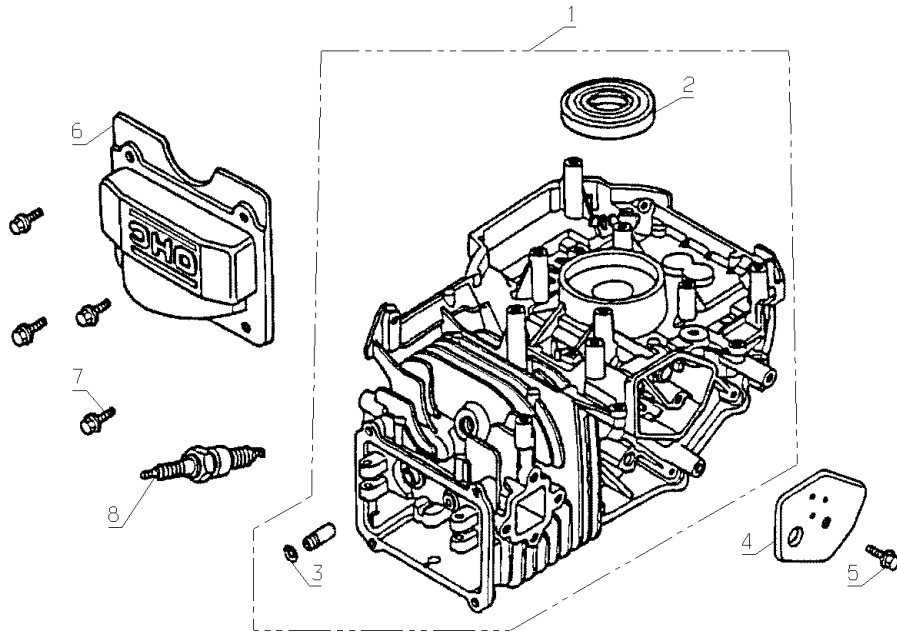

04/2005

Number	Part Number	Name	Quantity
1	18535	ROD ASSY CONNECTING	1,000
2	18537	SCREW	1,000
3	18538	CIRCLIPS 13MM	1,000
4	18534	PISTON PIN	1,000
5	18533	PISTON	1,000
6	18539	PISTON RING, SET OF	1,000
8	18530	CRANKSHAFT 160	1,000
9	18532	WASHER THRUST	1,000
10	18543	BELT	1,000
11	18541	PULLEY	1,000
12	18542	SHAFT	1,000
13	18554	O-RING 6,8X1,9	1,000
14	18546	ROCKER ARM EXHAUST	1,000
15	18553	NUT	1,000
16	18549	EXH. VALVE	1,000
17	18550	VALVE SPRING	1,000
18	18548	INLETVALVE	1,000
19	18551	VALVE CUP	1,000
20	18547	SHAFT	1,000
21	18545	ROCKER ARM INLET	1,000
22	18552	ADJUSTING SCREW	1,000
23	18540	CRANKSHAFT 160 D.25	1,000

HONDA
OHC 160

263.01

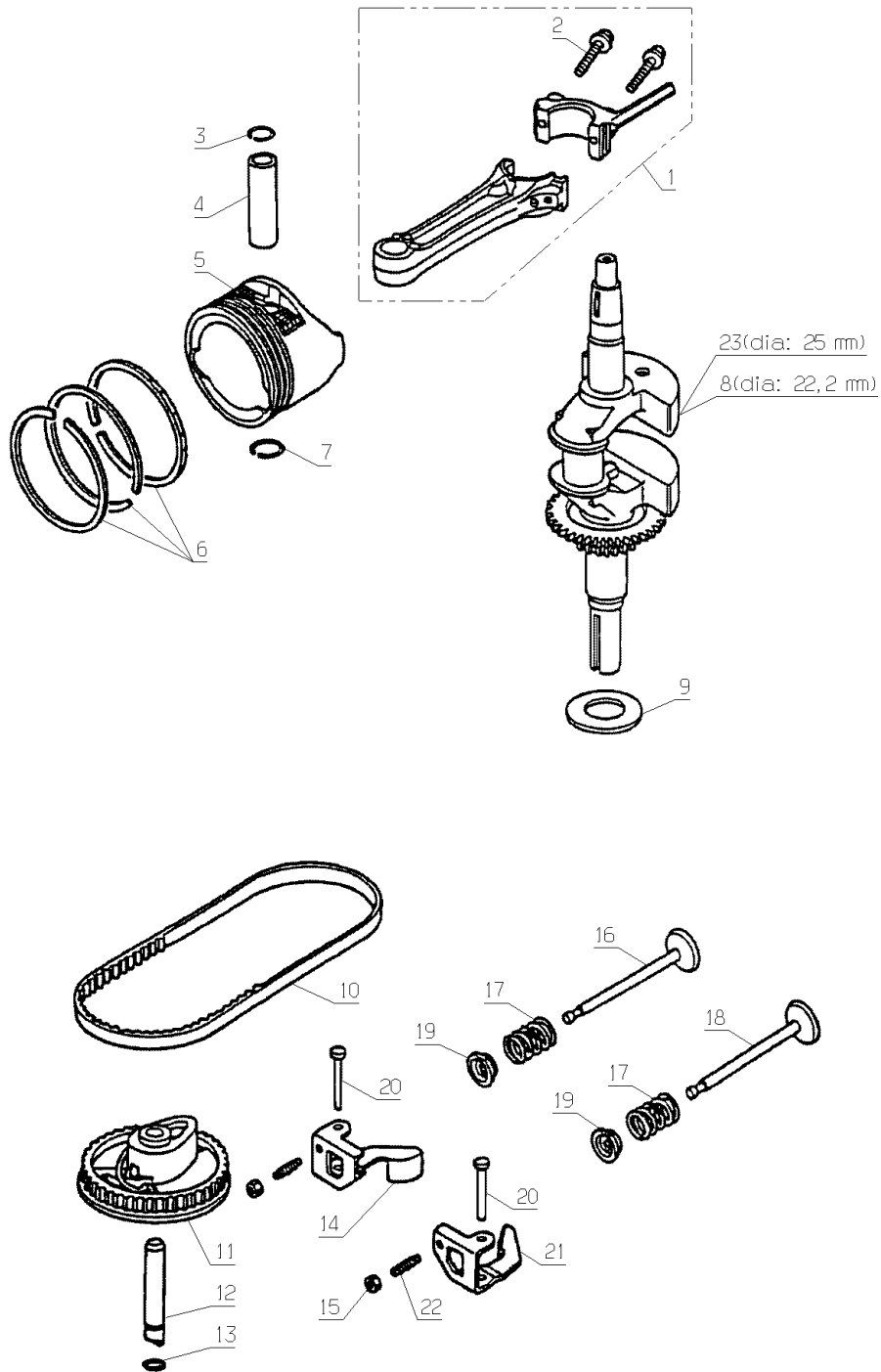

09/2008

Number	Part Number	Name	Quantity
1	18588	GASKET	1,000
2	18587	INSULATOR	1,000
3	18591	DEFLECTOR	1,000
4	18589	SEAL	1,000
5	18582	CARBURETOR 160	1,000
6	18593	SCREW	1,000
7	18579	ADJUSTING SCREW SET	1,000
8	18581	SCREW WITH SPRING	1,000
9	18585	CHOKE TUBE	1,000
10	18595	JET DIA.65	1,000
11	18584	FLOAT SPINDLE	1,000
12	18577	FLOAT	1,000
13	18576	GASKET SET	1,000
14	18578	FLOAT CHAMBER +SEAL	1,000
16	18580	SCREW WITH SEAL	1,000
17	18590	SEAL	1,000

HONDA
OHC 160

265.01

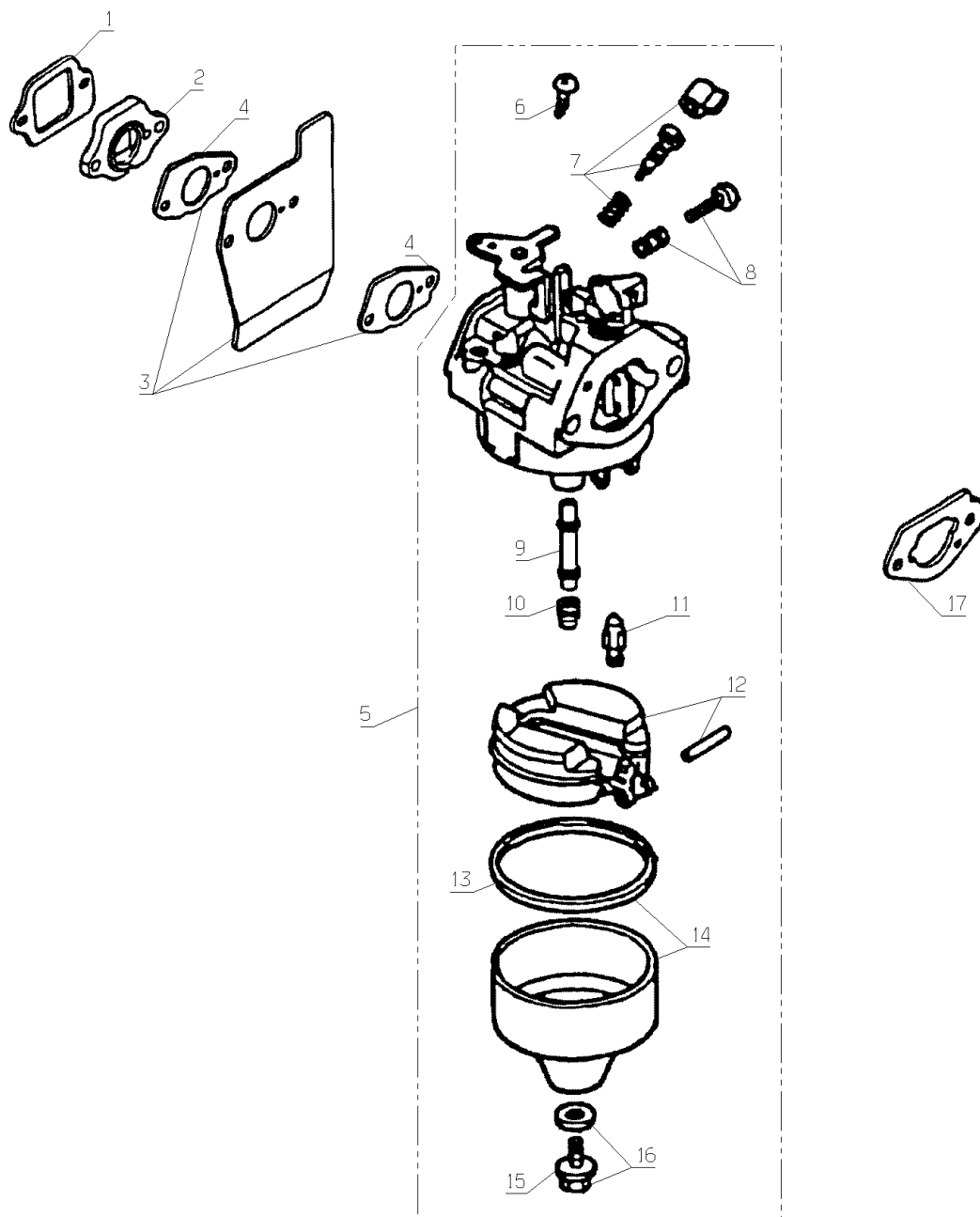

09/2008

Number	Part Number	Name	Quantity
1	18505	SCREW 6X12	1,000
2	18506	SCREW 6X14	1,000
3	18628	SPECIAL NUT 14MM	1,000
4	18620	WOODRUFF KEY	1,000
5	18623	FLYWHEEL	1,000
6	18627	SCREW	1,000
7	18622	COIL TRANSISTER	1,000
8	18625	GROUND CABLE	1,000
9	18629	BRACKET	1,000
10	18630	SCREW 4X12	1,000
11	18631	WASHER 4MM	1,000
12	18648	ROD, CHOKE	1,000
13	18626	SWITCH	1,000
14	18646	DRIVE PLATE ENG.BR.	1,000
15	18643	SPRING	1,000
16	18647	RETURN SPRING	1,000
17	18650	SCREW	1,000
18	18639	GOVERNOR SPRING	1,000
19	18649	SCREW LEVER	1,000
20	18651	SCREW 5X16	1,000
21	18644	CLAMP	1,000
22	18652	NUT 6MM	1,000
23	18636	REGULATOR LEVER	1,000
24	18641	RETURN SPRING	1,000
25	18637	GOVERNOR ROD	1,000
26	18621	FLANGE	1,000
27	18632	FLYWHEEL	1,000

HONDA
OHC 160

267.01

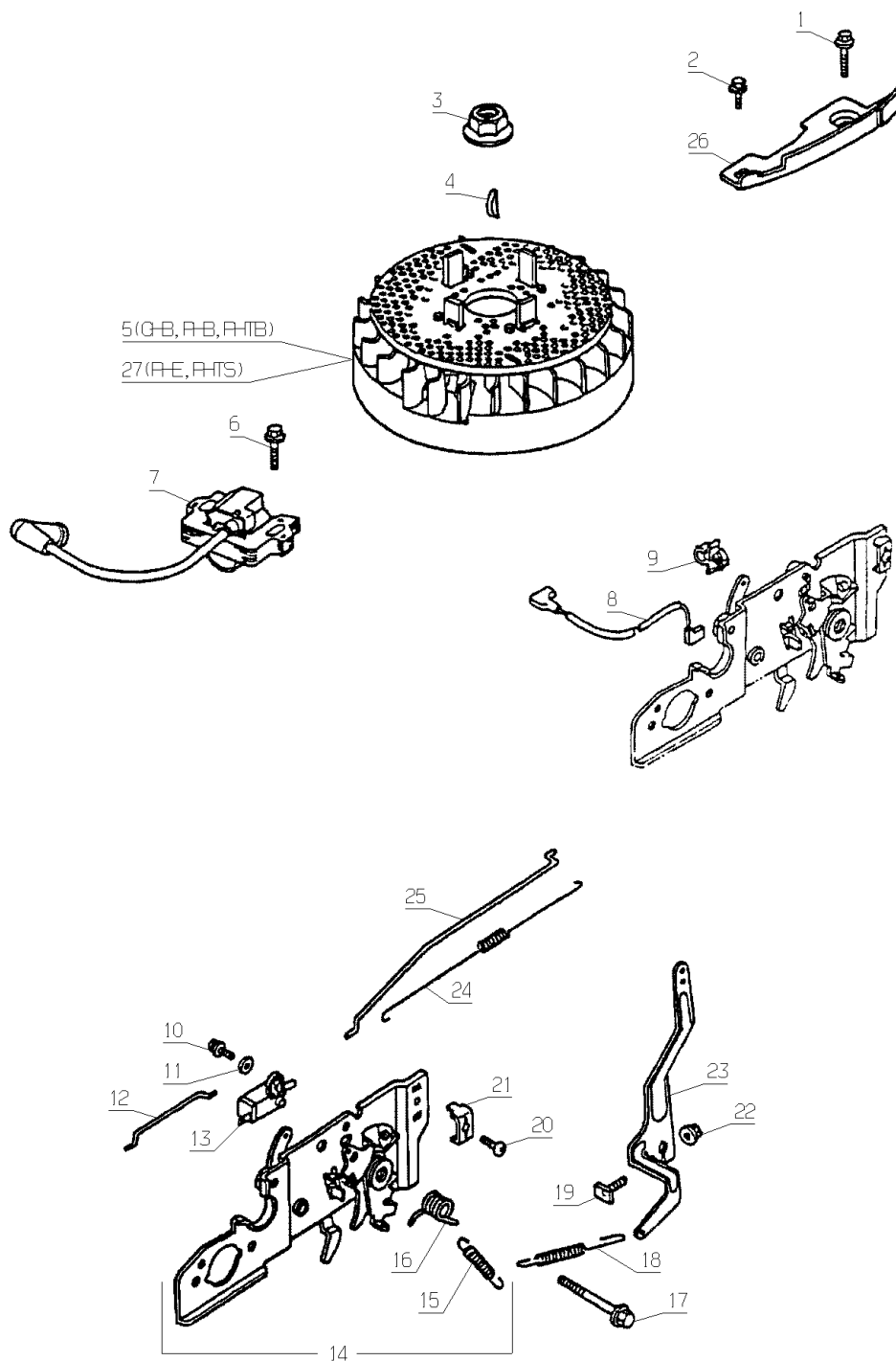

04/2005

Number	Part Number	Name	Quantity
1	18563	PLUG	1,000
2	18565	TANK CPL BLACK	1,000
3	18570	SCREW	1,000
4	18569	THREADED STUD	1,000
5	18567	RING	1,000
7	18560	RUBBER BRACKET	1,000
8	18573	CLIP	1,000
9	18564	HOSE	1,000
10	18558	NUT	1,000
11	18556	STARTER ASSY BLACK	1,000
12	18559	ROPE	1,000
13	18557	STARTER HANDLE	1,000
14	18574	CLIP	1,000
15	18572	HOSE 5,3X200	1,000
17	18561	COCK	1,000
18	18575	CLIP	1,000
19	18505	SCREW 6X12	1,000
20	18611	MISSION GUARD	1,000
21	18612	SCREW	1,000
22	18610	EXHAUST	1,000
23	18613	GASKET	1,000
24	18600	INLETTUBE	1,000
25	18603	FILTER GASKET	1,000
26	18602	FILTERBOX	1,000
27	18605	SCREW	1,000
28	18607	FILTER	1,000
29	18604	FILTER COVER	1,000
30	18606	SCREW	1,000

HONDA
GCV 160

269.01

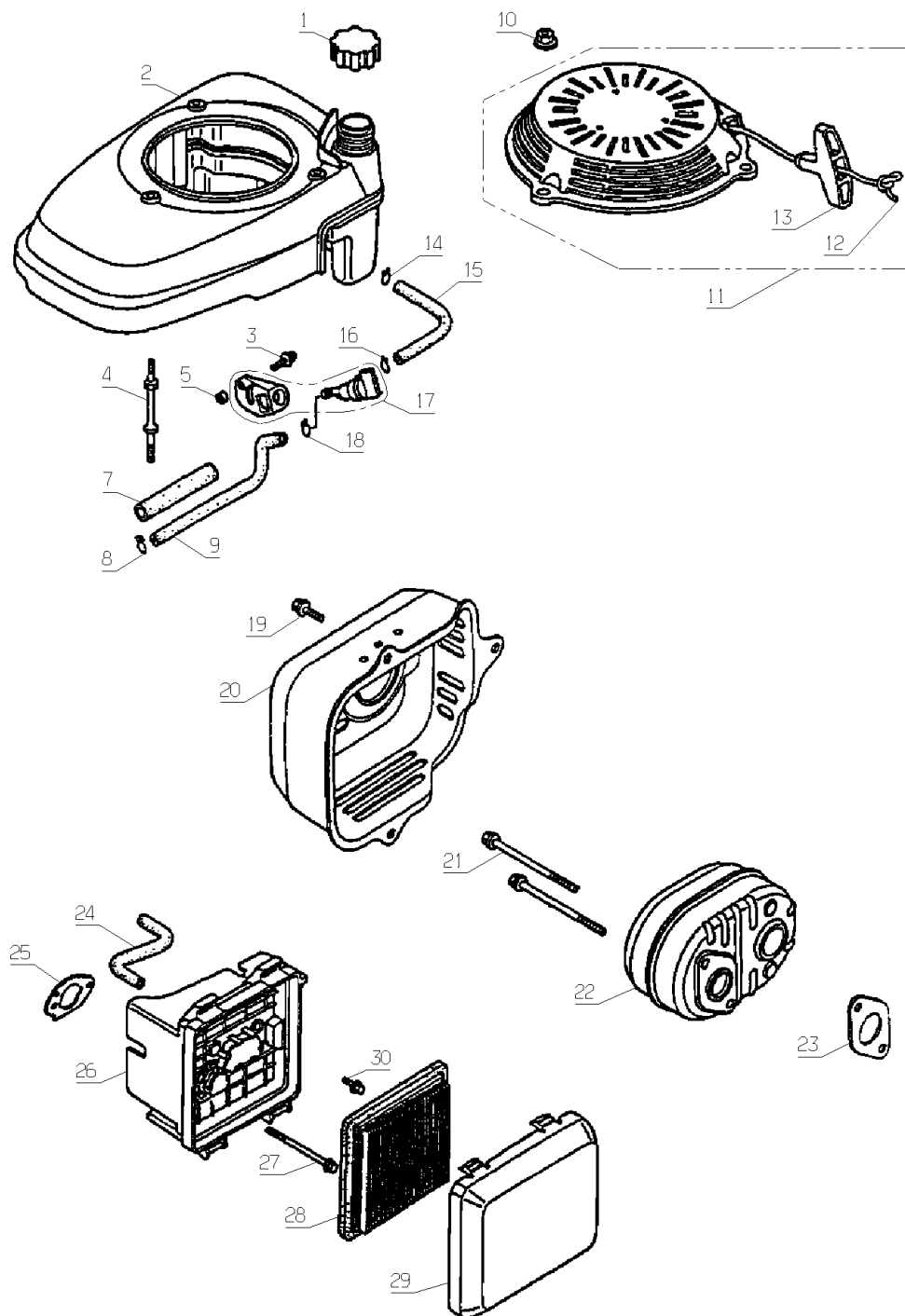

04/2009