

PARTS LIST

P/L No. 46014-501-00

REF. No.	PARTS No.	PARTS NAME	WHEEL		PRICE()	RECOMM.(%) Lot.100	REMARKS
			Q'TY	INCLUDING			
1	71041 112	WHEEL ASSY(R)	2				
2	91086 106	TIRE	2				
3	36107 101	WHEEL	2				
4	36070 110	CAP	2				
5							
6	61003 112	THRUST PLATE	2				
7	31034 137	PIN	2				
8							
9	68036 146	WASHER	2				
10	71158 101	RATCHET ASSY(R)	1				
11	11102 138	HOLDER	1				
12	31034 170	PIN	2				
13	68013 266	SPRING	1				
14	71158 102	RATCHET ASSY(L)	1				
15	11102 138	HOLDER	1				
16	31034 170	PIN	2				
17	68013 266	SPRING	1				
18							
19	31057 181	HEXAGON BOLT	2				
20	68036 101	WASHER	2				
21	11006 151	STAY C.P.(RL)	1				
22	11006 152	STAY C.P.(RR)	1				
23	342L 0612	FLANGE TAPPING BOLT	2				
24	31057 255	HEXAGON BOLT	2				
25	584L 0800	U-FLANGE NUT	2				
26	71122 112	ADJUSTER ASSY(L)	1				
27	11142 131	ADJUSTER(RL)	1				
28	945L 0349	BEARING	1				
29							
30	71122 113	ADJUSTER ASSY(R)	1				

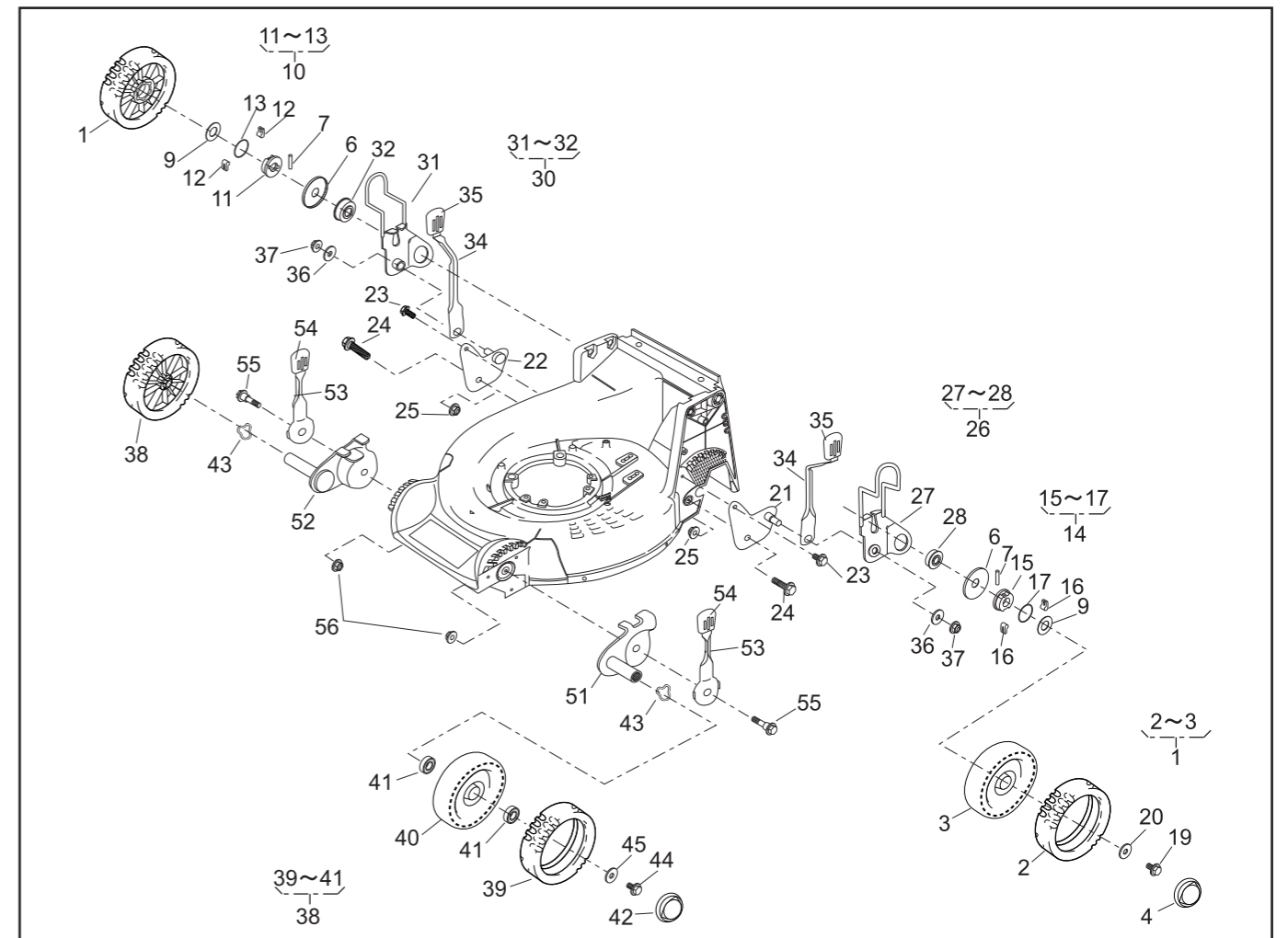

PARTS LIST

P/L No. 46014-501-00

REF. No.	PARTS No.	PARTS NAME	WHEEL		PRICE()	RECOMM.(%) Lot.100	REMARKS
			Q'TY	INCLUDING			
31	11142 132	ADJUSTER(RR)	1				
32	945L 0349	BEARING	1				
33							
34	11150 105 09	ADJUST LEVER	2				
35	36061 121	KNOB	2				
36	613L 0800	PLAIN WASHER	2				
37	569L 0800	FLANGE NYLON NUT	2				
38	71041 103	WHEEL ASSY(F)	2				
39	91086 106	TIRE	2				
40	36107 102	WHEEL	2				
41	932L 0696	BEARING	4				
42	36070 110	CAP	2				
43	664V 0626	WAVE SPRING WASHER	2				
44	31057 181	HEXAGON BOLT	2				
45	68036 101	WASHER	2				
46							
47							
48							
49							
50							
51	11142 134	ADJUSTER(FL)	1				
52	11142 135	ADJUSTER(FR)	1				
53	11150 107 09	ADJUST LEVER	2				
54	36061 121	KNOB	2				
55	31057 260	HEXAGON BOLT	2				
56	569L 0800	FLANGE NYLON NUT	2				
57							
58							
59							
60							

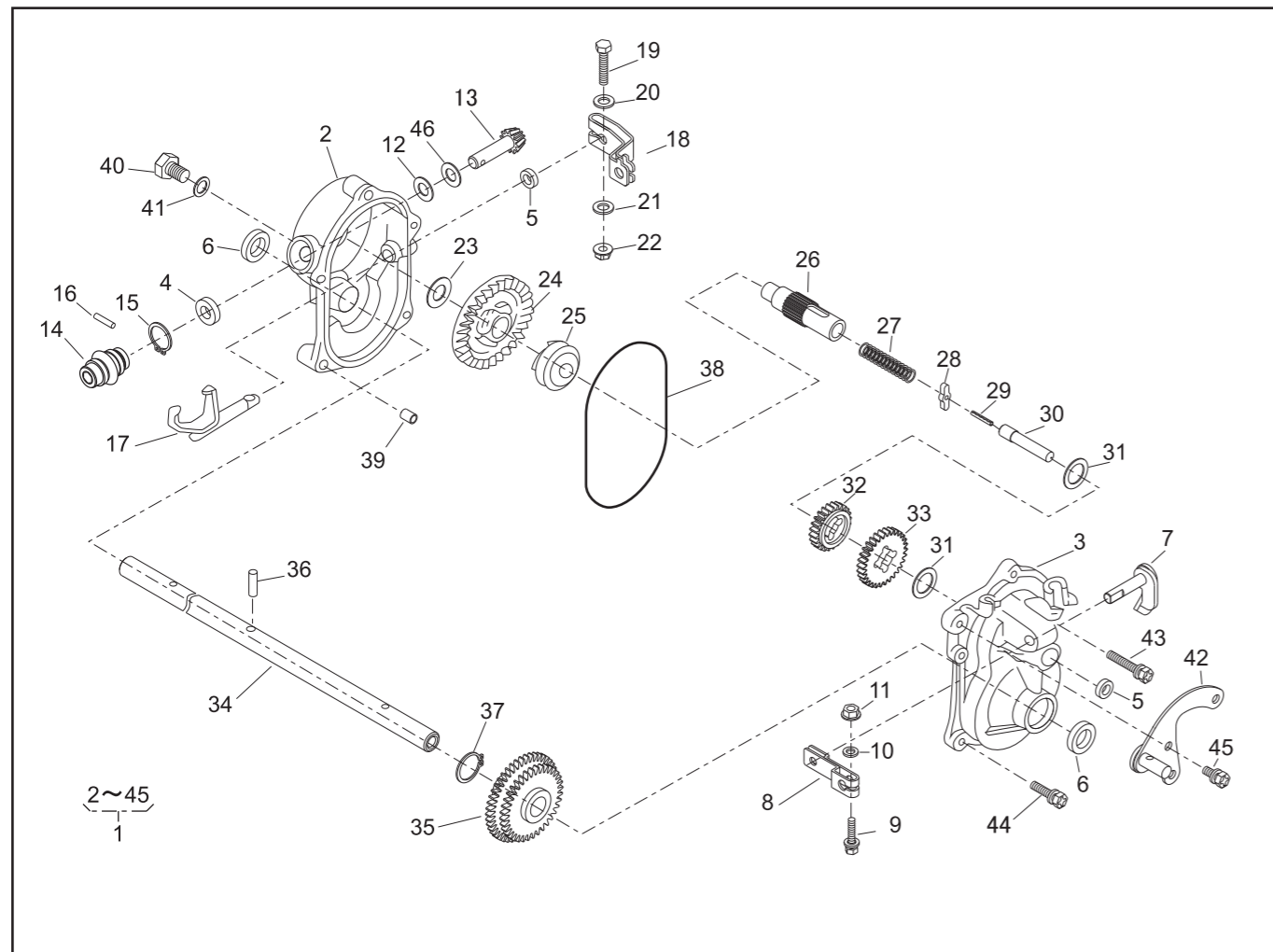

PARTS LIST
GEAR CASE ASSY (71008-275)

P/L No. 46014-262-04

REF. No.	PARTS No.	PARTS NAME	GEAR CASE		PRICE()	1/2		REMARKS
			Q'TY INCLUDING			RECOMM.(%) Lot.100	Dec. 25, 2006	
1	71008 275	GEAR CASE ASS'Y	1			-		
2	51001 195	GEAR CASE	1			3		
3	51001 196	GEAR CASE	1			3		
4	61002 161	OIL SEAL	1			5		SD 10 20 5
5	61002 162	OIL SEAL	2			5		SD 08 14 4
6	61002 163	OIL SEAL	2			5		SD 15 24 5
7	64024 104	SHIFTER SHAFT	1			3		
8	11104 119	ARM	1			3		
9	320L 0525	(+)HEXAGON BOLT (W/PW)	1			3		M5 × 25
10	611L 0500	PLAIN WASHER	1			3		M5
11	571L 0500	FLANGE NUT	1			3		M5
12	61003 109	THRUST PLATE	1			5		
13	78003 130	PINION	1			3		
14	91097 101	UNIVERSAL JOINT	1			3		
15	812V 2000	C-SNAP RING	1			1		φ 20
16	717B 0418	PARALLEL PIN	1			3		φ 4 × 18
17	11097 106	SHIFTER FORK	1			3		
18	11104 137	ARM	1			3		
19	311M 0630	HEXAGON BOLT	1			3		M6 × 30
20	611L 0600	PLAIN WASHER	1			3		M6
21	613L 0600	PLAIN WASHER	1			3		M6
22	571L 0600	FLANGE NUT	1			3		M6
23	61024 117	SPACER	1			5		
24	78001 162	BEVEL GEAR	1			3		
25	11129 107	CLUTCH	1			3		
26	64014 236	SHAFT	1			3		
27	68013 262	SPRING	1			3		

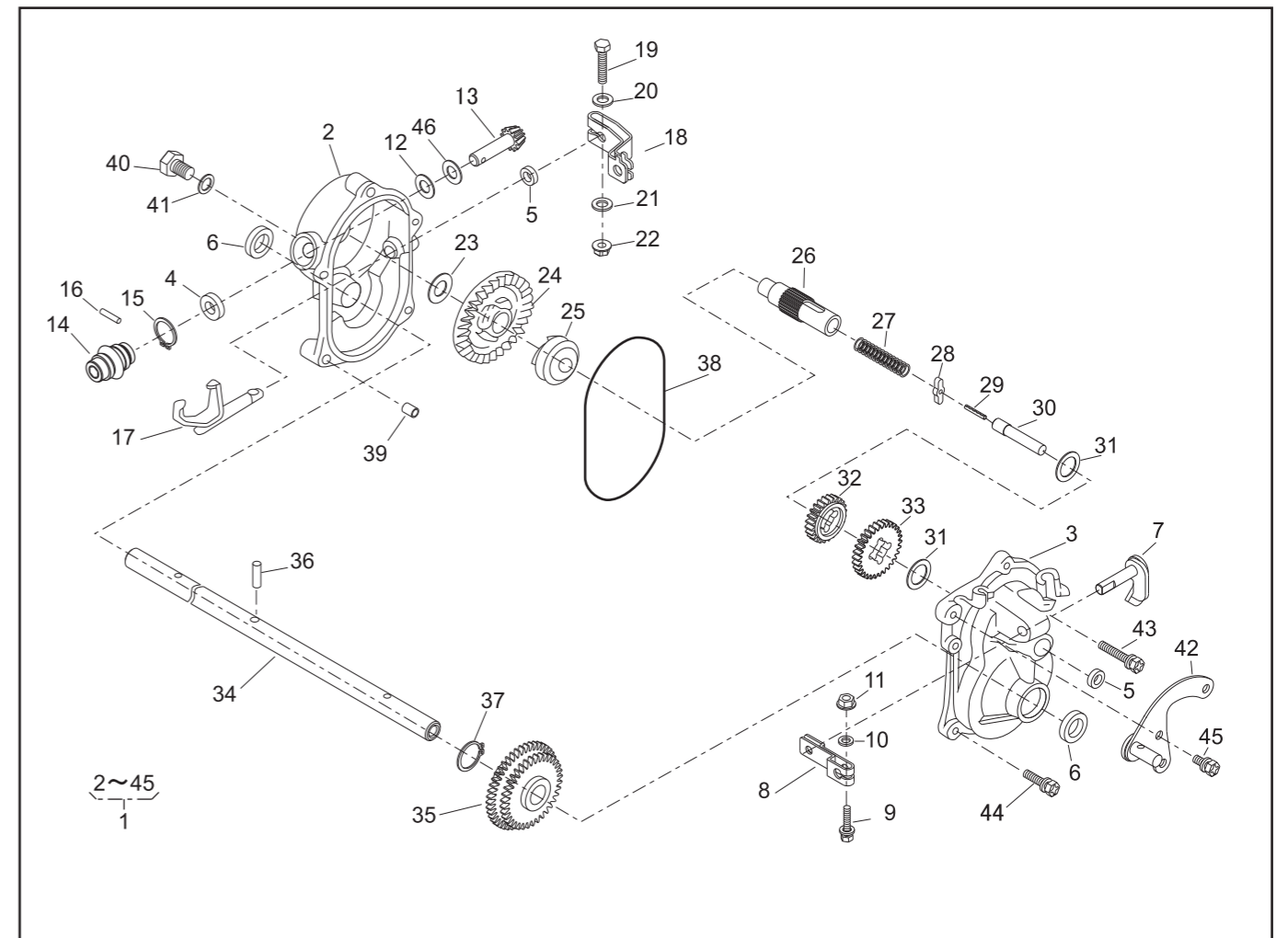

PARTS LIST
GEAR CASE ASSY (71008-275)

P/L No. 46014-262-04

REF. No.	PARTS No.	PARTS NAME	GEAR CASE		PRICE()	2/2		REMARKS
			Q'TY INCLUDING			RECOMM.(%) Lot.100	Dec. 26, 2006	
28	31034 171	PIN	1			3		
29	736U 0320	SPRING PIN	1			3		
30	64014 235	SHAFT	1			3		
31	61024 118	SPACER	2			3		
32	78004 156	GEAR	1			3		
33	78004 155	GEAR	1			3		
34	64014 163	SHAFT	1			3		
35	78012 107	GEAR C.P.	1			3		
36	31034 150	PIN	1			3		
37	812V 2200	C-SNAP RING	1			1		φ 22
38	214B 11000	O-RING	1			5		S110
39	11083 201	COLLAR	2			5		
40	31057 262	HEXAGON BOLT	1			3		M10 × 1.25
41	68001 110	FIBER WASHER	1			3		
42	11006 165	STAY C.P.	1			5		
43	315L 0625	(+)HEXAGON BOLT (W/SW,PW)	3			3		M6 × 25
44	315L 0635	(+)HEXAGON BOLT (W/SW,PW)	2			3		M6 × 35
45	318L 0612	(+)HEXAGON BOLT (W/SW)	1			3		M6 × 12
46	68007 132	SHIM	0~2			3		

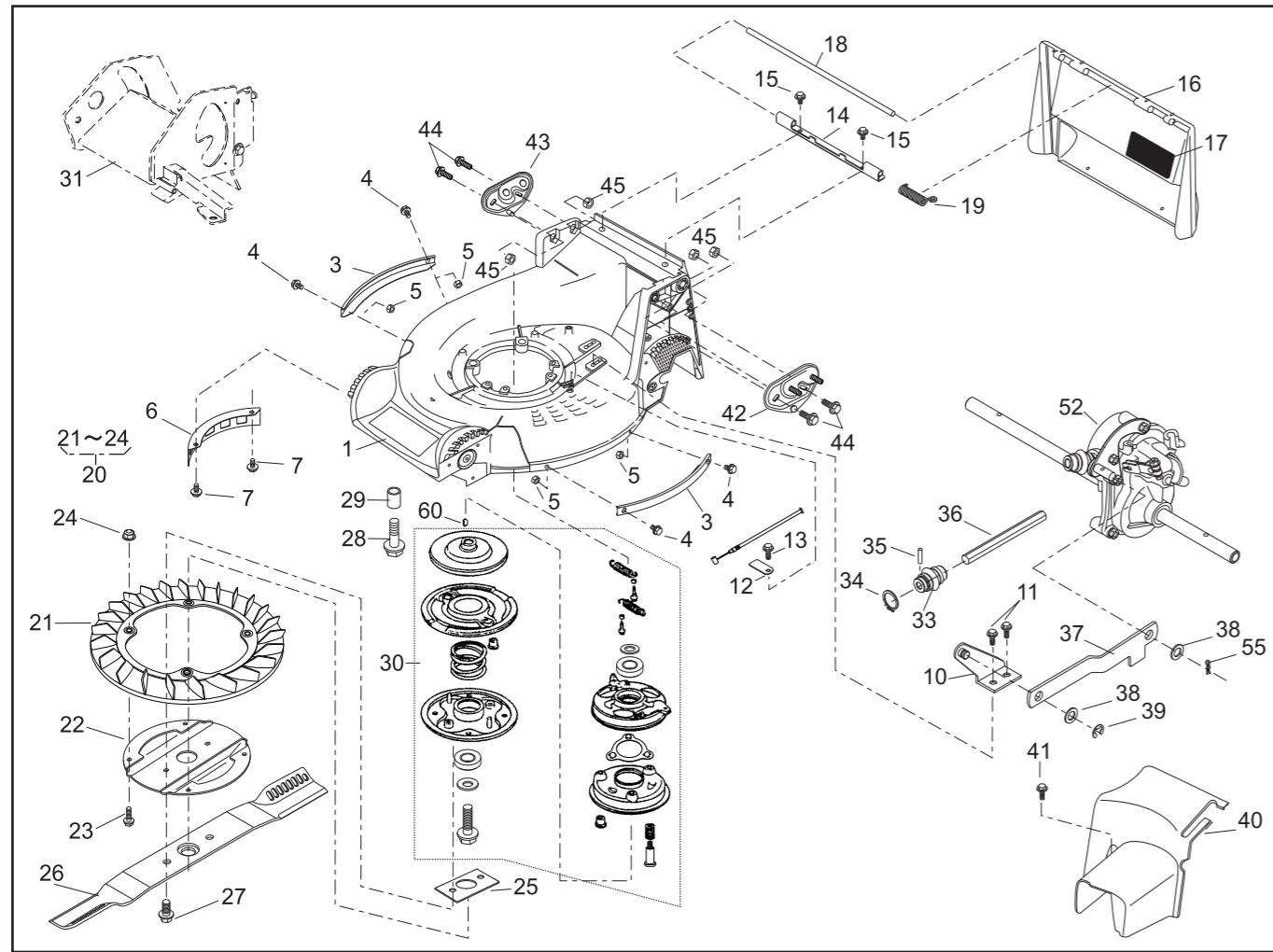

PARTS LIST

P/L No. 46014-533-00

NOTE	REF. No.	PARTS No.	PARTS NAME	GRASS-CUTTING		PRICE()	RECOMM.(%) Lot.100	REMARKS
				Q'TY	INCLUDING			
	1	51043 152 42	HOUSING	1				
	2							
	3	51090 117 09	PROTECTOR	2				
	4	335L 0616	FLANGE BOLT	4				
	5	512L 0600	HEXAGON NUT	4				
	6	36065 180	COVER	1				
	7	342L 0612	FLANGE TAPPING BOLT	2				
	8							
	9							
	10	11006 155	STAY C.P.	1				
	11	342L 0612	FLANGE TAPPING BOLT	2				
	12	11113 407	STAY	1				
	13	342L 0612	FLANGE TAPPING BOLT	1				
	14	11113 292	STAY	1				
	15	342L 0612	FLANGE TAPPING BOLT	2				
	16	36068 196 46	GUARD	1				
	17	36080 149	RUBBER SHEET	1				
	18	64014 324	SHAFT	1				
	19	68013 336	SPRING	1				
	20	71082 111	FAN ASS'Y	1				
	21	51125 103	FAN	1				
	22	11102 151	HOLDER	1				
	23	31062 169	PRE-COAT LOCK BOLT	4				
	24	579L 0600	FLANGE NUT	4				
	25	61024 208	SPACER	1				
	26	91014 188	BLADE	1				
	27	31057 197	HEXAGON BOLT	2				
	28	31057 243	HEXAGON BOLT	4				
	29	61024 142	SPACER	3				
	30	71067 106	BRAKE ASS'Y	1				

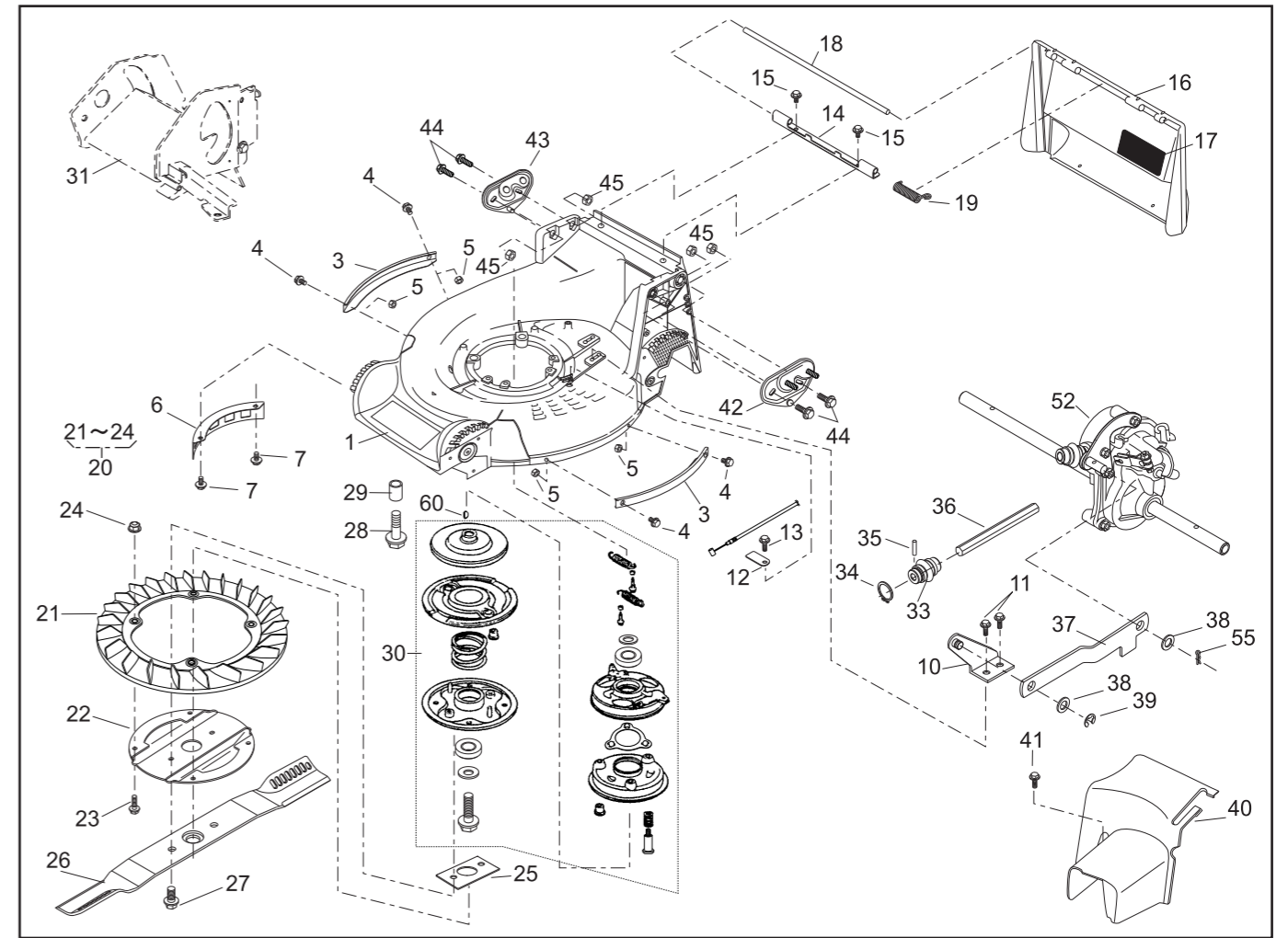

PARTS LIST

P/L No. 46014-533-00

NOTE	REF. No.	PARTS No.	PARTS NAME	GRASS-CUTTING		PRICE()	RECOMM.(%) Lot.100	REMARKS
				Q'TY	INCLUDING			
	31		COVER UNIT (Ref. P/L No. 46012-548-**)					
	32							
	33	91097 101	UNIVERSAL JOINT	1				
	34	812V 2000	C-SNAP RING	1				
	35	717B 0418	PARALLEL PIN	1				
	36	64014 358	SHAFT	1				
	37	91049 135	CONNECTOR	1				
	38	68036 280	WASHER	2				
	39	816V 0800	E-SNAP RING	1				
	40	36065 438	COVER	1				
	41	342L 0616	FLANGE TAPPING BOLT	1				
	42	51116 149	HANDLE BRACKET(L)	1				
	43	51116 150	HANDLE BRACKET(R)	1				
	44	31057 255	HEXAGON BOLT	4				
	45	512L 0800	HEXAGON NUT	4				
	46							
	47							
	48							
	49							
	50							
	51							
	52	71008 275	GEAR CASE ASS'Y	1				
	53							
	54							
	55	733L 1000	SNAP PIN	1				
	56							
	57							
	58							
	59	122039	ENGINE:HONDA GXV160H2-SFL1-R280	1				
	60		WOODRUFF KEY	1				

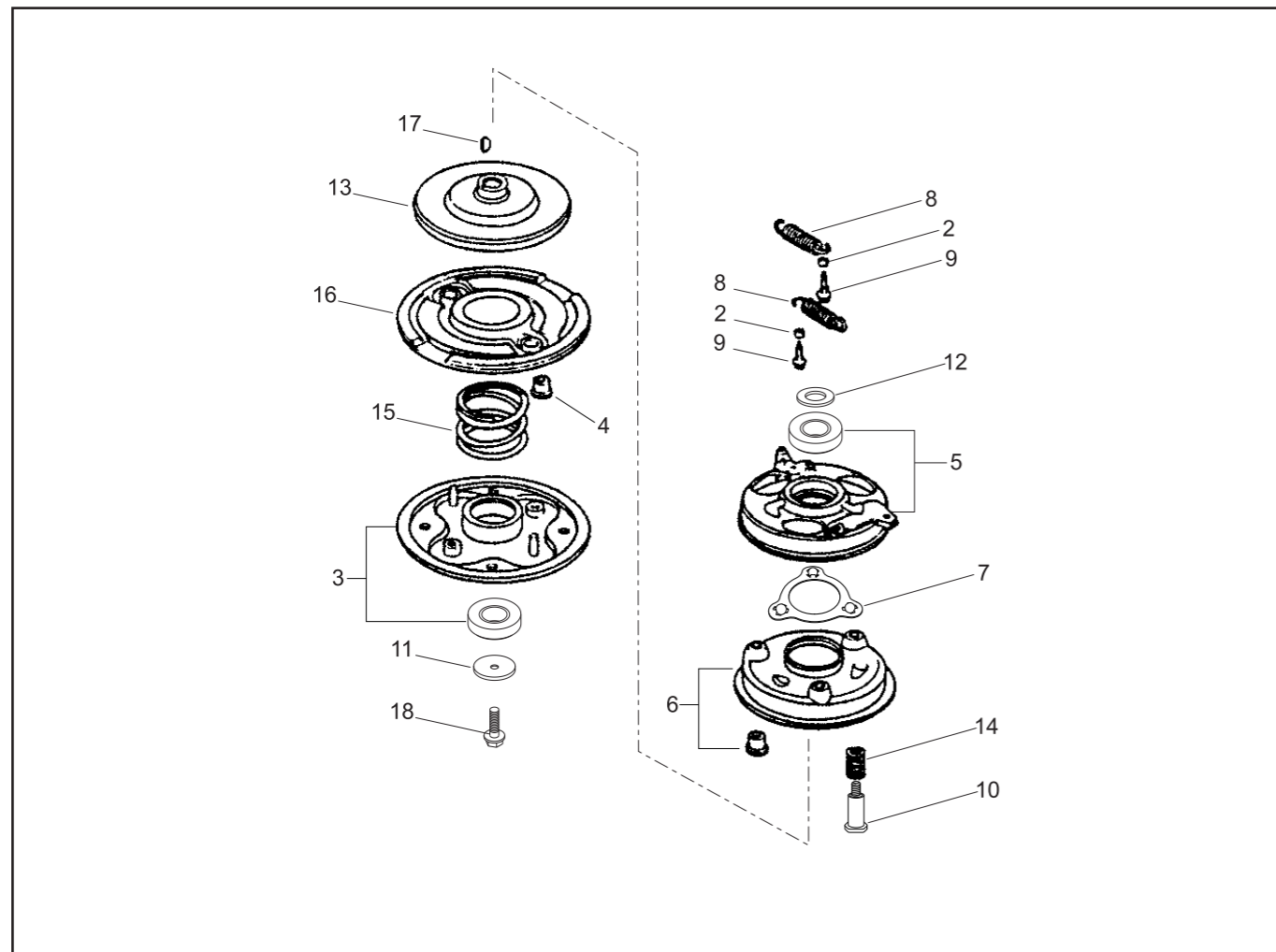

PARTS LIST

BRAKE ASSY (71067-106)

P/L No. 46014-266-02

REF. No.	PARTS No.	PARTS NAME	BBC		1/1	Feb.09,2005	REMARKS
			Q'TY INCLUDING	PRICE()	RECOMM.(%) Lot.100		
1	71067 106	BRAKE ASS'Y	1				
2	19512 883 000	FAN COLLAR	2				
3	72600 VA4 010	HOLDER ASS'Y	1				
4	72613 VA4 000	BUSH, BLADE HOLDER	2				
5	75090 VA4 030	CONTROL ASS'Y	1				
6	75100 VA4 010	BRAKE C.P.	1				
7	75110 VA4 000	BALL RETAINER C.P.	1				
8	75182 VA3 J00	SPRING, CLUTCH RETURN	2				
9	90014 952 000	FLANGE BOLT	2				6 x 14
10	90021 VA4 000	BOLT, SPECIAL	3				6 mm
11	90409 952 000	WASHER	1				10 mm
12	90501 952 010	THRUST WASHER	1				
13	75130 VA4 000	BRAKE DISK	1				
14	75132 VA4 000	SPRING, BRAKE HOLDER	3				
15	75183 VA3 J00	SPRING, CLUTCH	1				
16	75150 VA3 J01	DRIVEN DISK C.P.	1				
17	94401 16150	WOODRUFF KEY	1				
18	90105 960 003	BOLT (10x25)	1				
19							
20							
21							
22							
23							
24							
25							
26							
27							
28							