

This catalog covers:
FJ151V-□C50

This fig. covers:
TITLE

PARTS CATALOG

4-STROKE ENGINE

FJ151V

PRODUCT CODE	NOTE
FJ151V-AC50	MOWER
	(LM4851)

This catalog covers:
FJ151V-□C50

PARTS CATALOG INTRODUCTION

This parts catalog lists parts and sub-assemblies provided as service parts.

When it becomes necessary to replace parts, always use KAWASAKI GENUINE PARTS which have passed strict inspection which guarantees quality and performance.

1. HOW TO ORDER PARTS

- When ordering the parts, be sure to use the parts catalog corresponding to the product code. Check the product revision codes on the product and the catalog.
 Product Code (example) : FA130D-AA00
└── Product Revision Code
- Specify the part code (all digits) exactly as listed in this catalog on your parts order.
- The parts not shown in the illustrations of this catalog are not sold separately; only the complete units or next higher assemblies illustrated are supplied as the service parts.

2. EXPLANATION OF PARTS CATALOG FORMAT

This catalog covers: **TH026D-□A10** (1)

This fig. covers: **01 CYLINDER/CRANKCASE** (2) (5) (7)

Ref. No.	Part No.	Description	Quantity
11005	11005-2137	CYLINDER-ENGINE	1
11060	11060-2402	GASKET,CYLINDER	1
11065	11065-2064	CAP	2
14002	14002-2327	CRANKCASE	1
14002A	14002-2328	CRANKCASE	1
34001	34001-2083	STAND	1
92009	92009-2115	SCREW	3
92045	92045-1302	PIN	2
92045	92045-2006	BEARING-BALL,6000C3	2
92049	92049-2074	SEAL-OIL	2
92150	92150-2091	BOLT	4

(6)

1) Product Code

This code describes the product code covered by this catalog. The product revision code, which is a part of the product code, is omitted.

2) Part Group Title

This title is the representative name for the group of parts illustrated on the page.

3) Reference Number

The reference numbers are shown on the illustration and the list as the link between them.

This fig. covers:

PARTS LIST INFORMATION

4) Part Number

This is the key of your parts ordering.

Three kinds of part number are used in this catalog.

a. Structure 1

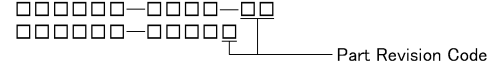

b. Structure 2

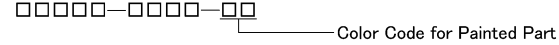

c. Standard Hardware Number

(for bolts, nuts, washer, or the like)

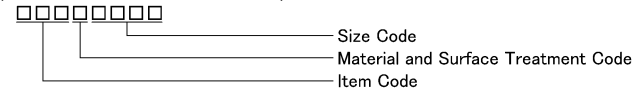

5) Description and Additional Information

The part name, the location, the size, and the serial number as additional information, etc. are described here. Use them to find out and check the part required.

When a part number is changed without change of the product revision code and the changed parts are not interchangeable, the serial number of the product is noted as follows;

- (FA130 - 100001) : Affected units are from beginning of the product of the product code up to and including this serial number.
- (FA130 - 100002 -) : Affected units are from this serial number and above.
- (FA130 - 100002 - FA130 - 110001) : Affected units are in this serial number range.

6) Quantity

The figure shows quantity of the part required at the indicated position on the illustration and for the specified product revision code.

The asterisk (*) on this column means the part can be used as the substitute on the product and is supplied until the stock is exhausted.

Note:Some small parts will be supplied by units.

Example: If six (6) bolts are ordered and the minimum quantity per unit is five (5), two (2), units of the bolt will be delivered.

7) Product Revision Code

This Code indicates an important change which affects the service parts interchangeability.

3. ABBREVIATIONS

#.....Number	FR.....Front	RH.....Right Hand
&.....And	G.....Gram	RPM.....Revolutions Per Minute
(+).....Plus	HEX.....Hexagonal	RR.....Rear
(-).....Minus	ID=.....Inside Diameter	STD.....Standard
2ND.....Second	IN.....Inch	T.....Teeth
3RD.....Third	L=.....Length	T=.....Thickness
4TH.....Fourth	LH.....Left Hand	U/S.....Under Size
A.....Ampere	LWR.....Lower	UPP.....Upper
AR.....As Required	MM.....Millimeter	V.....Volt
ASSY.....Assembly	O/S.....Over Size	W.....Watt
CNT.....Center	OD=.....Outside Diameter	
COMP.....Complete	REF.....Reference	

This catalog covers:

FJ151V- □ C50

This fig. covers:

01 CYLINDER/CRANKCASE

E0110-A472L

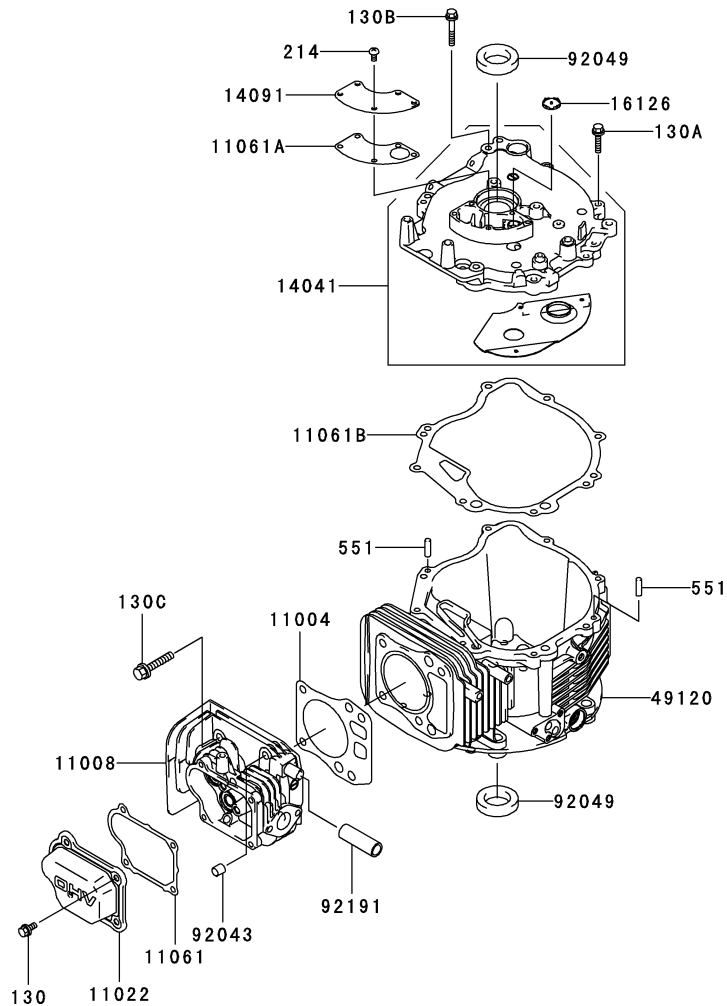

Ref. No.	Part No.	Description	Quantity
11004	11004-7020	GASKET-HEAD	1
11008	11008-7025	HEAD-COMP-CYLINDER	1
11022	11022-7005	CASE-ROCKER	1
11061	11061-7023	GASKET,CASE ROCKER	1
11061A	11061-7031	GASKET,BREATHER	1
11061B	11061-7051	GASKET,COVER-CRANKCASE	1
14041	14041-7004	COVER-COMP	1
14091	14091-7010	COVER,BREATHER	1
16126	16126-7014	VALVE,BREATHER	1
49120	49120-7046	CRANKCASE-COMP	1
92043	92043-7001	PIN	2
92049	92049-7008	SEAL-OIL,28-44-9 TC	2
92191	92191-7025	TUBE,12X16X49	1
130	130B0612	BOLT-FLANGED,6X12	4
130A	130G0625	BOLT-FLANGED,6X25	7
130B	130G0635	BOLT-FLANGED,6X35	1
130C	130T0840	BOLT-FLANGED,8X40	4
214	214B0510	SCREW-PAN+,-,5X10	5
551	551A0612	PIN-DOWEL,6X12	2

This catalog covers:

FJ151V- □ C50

This fig. covers:

02 PISTON/CRANKSHAFT

E0120-A266A

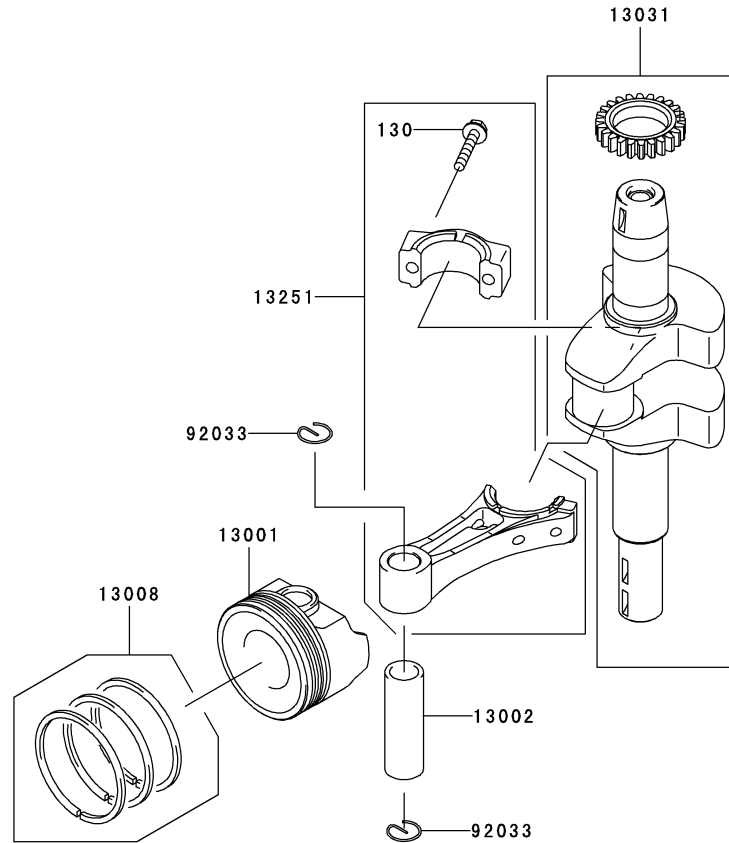

Ref. No.	Part No.	Description	Quantity
13001	13001-7009	PISTON-ENGINE	1
13002	13002-7001	PIN-PISTON	1
13008	13008-6065	RING-SET-PISTON	1
13031	13031-7066	CRANKSHAFT-COMP	1
13251	13251-7011	ROD-ASSY-CONNECTING	1
92033	92033-7005	RING-SNAP	2
130	130G0630	BOLT-FLANGED,6X30	2

This catalog covers:

FJ151V- □ C50

03

This fig. covers:

VALVE/CAMSHAFT

E0130-A135B

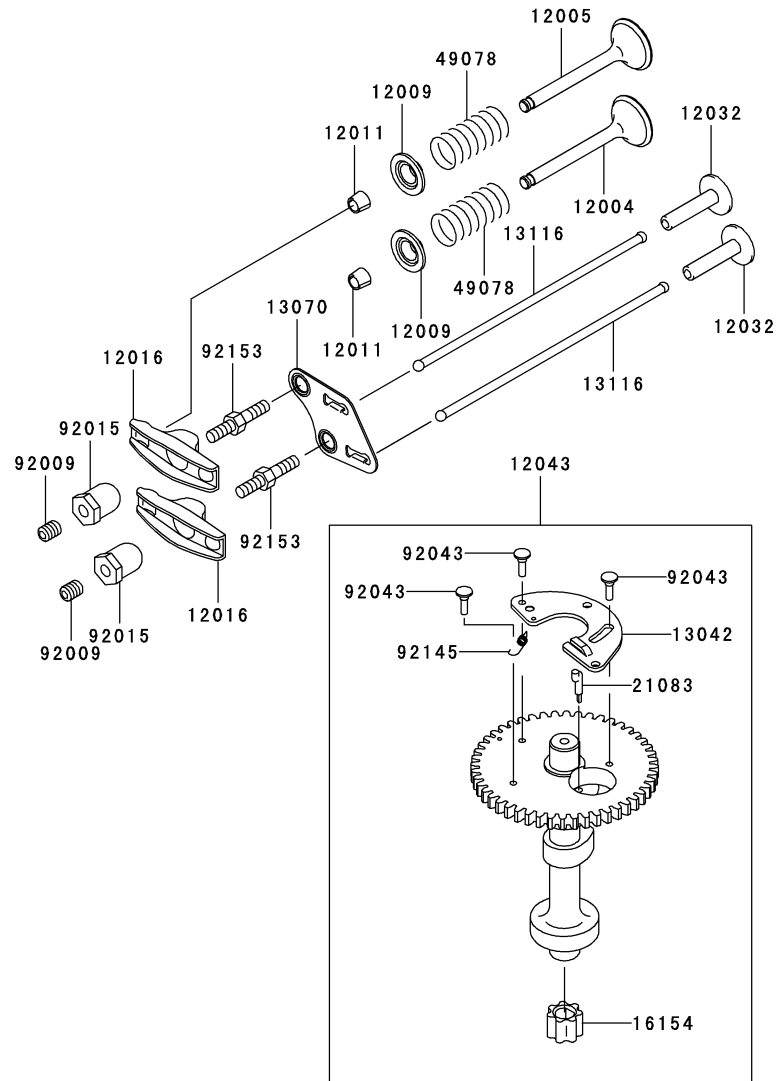

Ref. No.	Part No.	Description	Quantity
12004	12004-7005	VALVE-INTAKE	1
12005	12005-7006	VALVE-EXHAUST	1
12009	12009-7001	RETAINER-VALVE SPRING	2
12011	12011-2056	COLLET	4
12016	12016-7008	ARM-ROCKER	2
12032	12032-7001	TAPPET	2
12043	12043-7005	CAMSHAFT-ASSY-VALVE	1
13042	13042-7006	WEIGHT	1
13070	13070-7009	GUIDE	1
13116	13116-7003	ROD-PUSH	2
16154	16154-7004	ROTOR-PUMP	1
21083	21083-7009	ARM	1
49078	49078-7001	SPRING-ENGINE VALVE	2
92009	92009-2341	SCREW	2
92015	92015-2253	NUT	2
92043	92043-7006	PIN	3
92145	92145-7016	SPRING	1
92153	92153-7019	BOLT	2

This catalog covers:
FJ151V- □ C50

This fig. covers:
04 LUBRICATION-EQUIPMENT

E0140-A287E

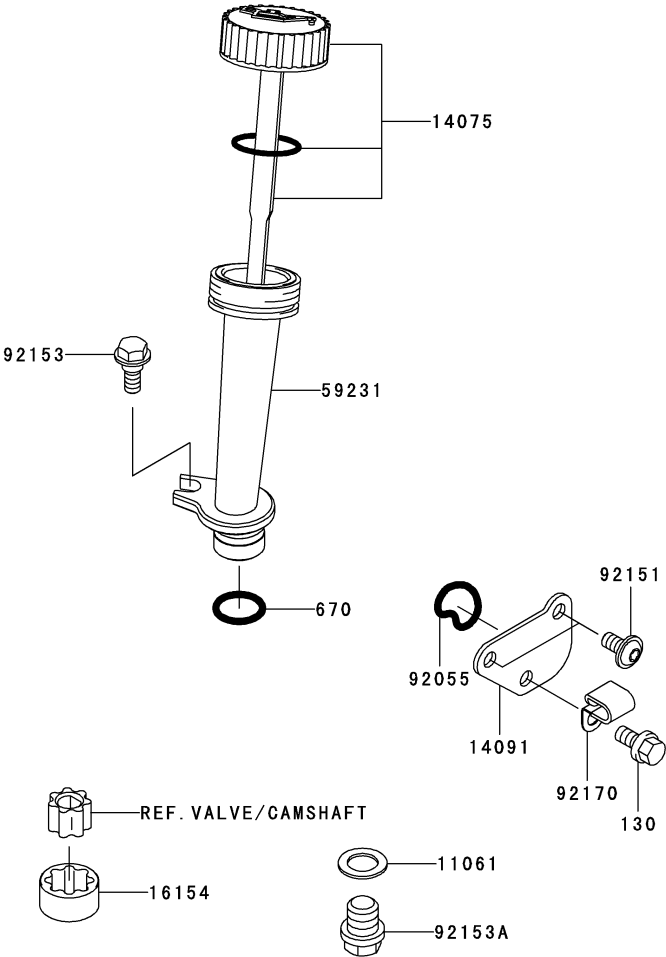

Ref. No.	Part No.	Description	A	Quantity
11061	11061-7030	GASKET,12X19X1.27		1
14075	14075-7007	CAP-ASSY		1
14091	14091-7011	COVER,OIL FILTER		1
16154	16154-7002	ROTOR-PUMP		1
59231	59231-7004	FILLER		1
92055	92055-2151	RING-O		1
92151	92151-7012	BOLT,6X12		2
92153	92153-7007	BOLT		1
92153A	92153-7016	BOLT,12X12		1
92170	92170-1577	CLAMP		1
130	130B0612	BOLT-FLANGED,6X12		1
670	670D2016	O RING,16MM		1

This catalog covers:
FJ151V- □ C50

This fig. covers:
05 COOLING-EQUIPMENT

E0150-A643C

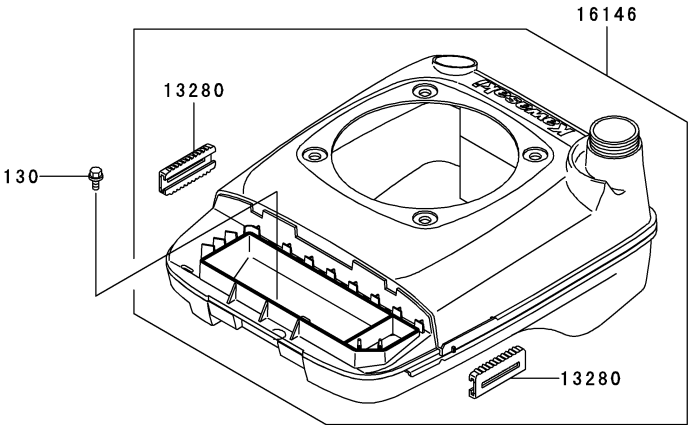

Ref. No.	Part No.	Description	Quantity
11053	11053-7009	BRACKET,FAN	1
13280	13280-7001	HOLDER	2
14037	14037-7017	SCREEN	1
16146	16146-7018	COVER-ASSY	1
59041	59041-7009	FAN	1
59066	59066-7016	HOUSING-FAN	1
130	130B0612	BOLT-FLANGED,6X12	2

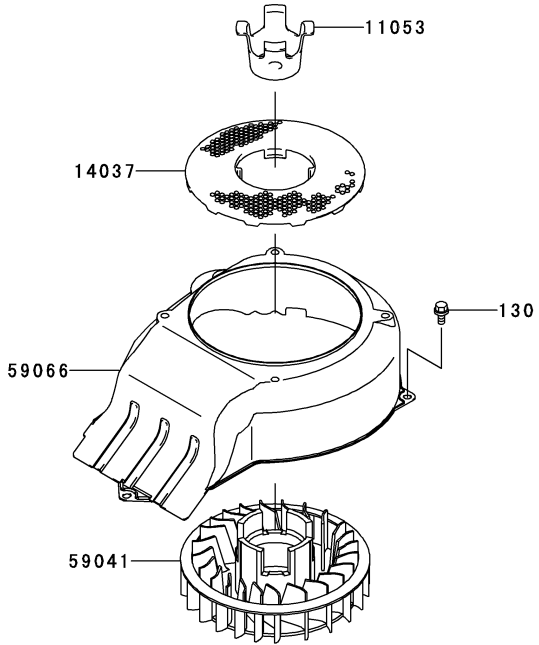

This catalog covers:

FJ151V- □ C50

06

This fig. covers:

ELECTRIC-EQUIPMENT

E0160-B037A

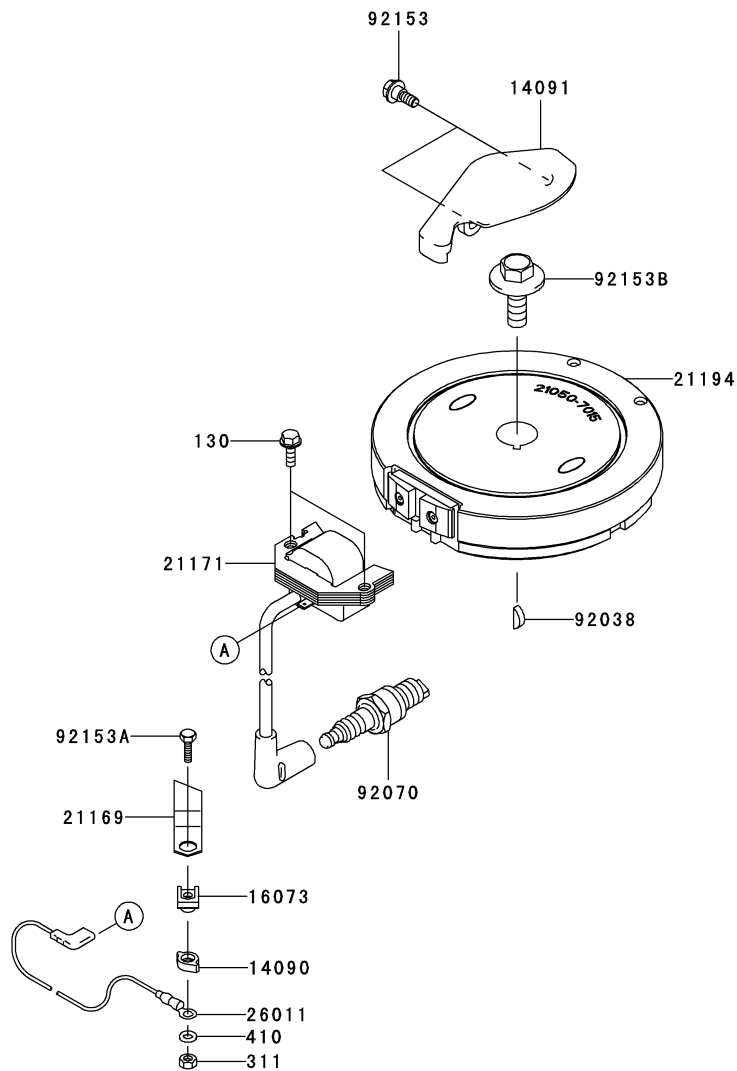

Ref. No.	Part No.	Description	Quantity
14090	14090-2108	COVER	1
14091	14091-7036	COVER	1
16073	16073-2192	INSULATOR	1
21169	21169-2071	TERMINAL	1
21171	21171-7021	COIL-ASSY-IGNITION	1
21194	21194-7024	FLYWHEEL-COMP	1
26011	26011-7013	WIRE-LEAD	1
92038	92038-2077	KEY	1
92070	92070-2088	PLUG-SPARK,BPR5ES(NGK),SOLID	1
92153	92153-7007	BOLT	2
92153A	92153-7012	BOLT,4X16	1
92153B	92153-7030	BOLT,12X30	1
130	130B0620	BOLT-FLANGED,6X20	2
311	311B0400	NUT-HEX,4MM	1
410	410B0400	W-PLAIN-S,4MM	1

This catalog covers:

FJ151V- □ C50

This fig. covers:

07 CONTROL-EQUIPMENT

E0170-A478E

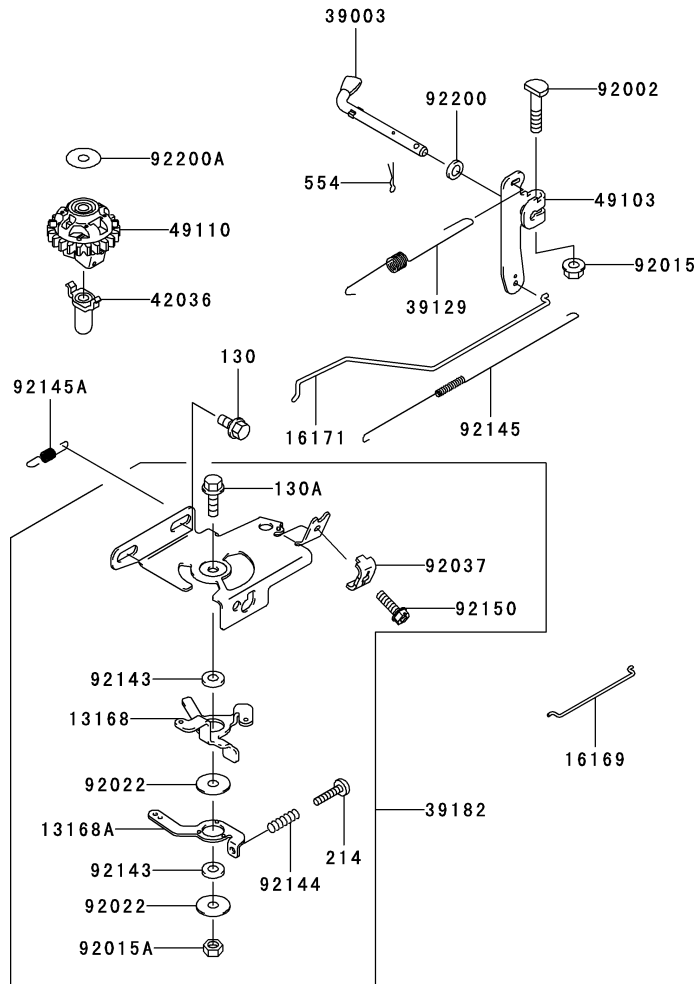

Ref. No.	Part No.	Description	Quantity
13168	13168-7020	LEVER	1
13168A	13168-7022	LEVER	1
16169	16169-7011	LINK-CHOKE	1
16171	16171-7015	LINK, THROTTLE	1
39003	39003-7002	ARM-PIVOT	1
39129	39129-7014	SPRING-GOVERNOR	1
39182	39182-7005	PANEL-ASSY-CONTROL	1
42036	42036-2051	SLEEVE	1
49103	49103-7005	ARM-GOVERNOR	1
49110	49110-7002	GOVERNOR-ASSY	1
92002	92002-2269	BOLT, 6X28	1
92015	92015-1193	NUT	1
92015A	92015-2051	NUT	1
92022	92022-2372	WASHER, 6X19X1.2	2
92037	92037-2209	CLAMP	1
92143	92143-2135	COLLAR, 6X13X2.3	2
92144	92144-2266	SPRING	1
92145	92145-7025	SPRING, THROTTLE	1
92145A	92145-7032	SPRING	1
92150	92150-2182	BOLT, 5X18	1
92200	92200-2029	WASHER, 6.5X11.5X2.0	1
92200A	92200-2036	WASHER, 6.2X20X0.5	1
130	130B0612	BOLT-FLANGED, 6X12	2
130A	130B0618	BOLT-FLANGED, 6X18	1
214	214B0420	SCREW-PAN+, 4X20	1
554	554A0600	PIN-SNAP, 1.2X21.2	1

This catalog covers:

FJ151V- □ C50

08

This fig. covers:

CARBURETOR

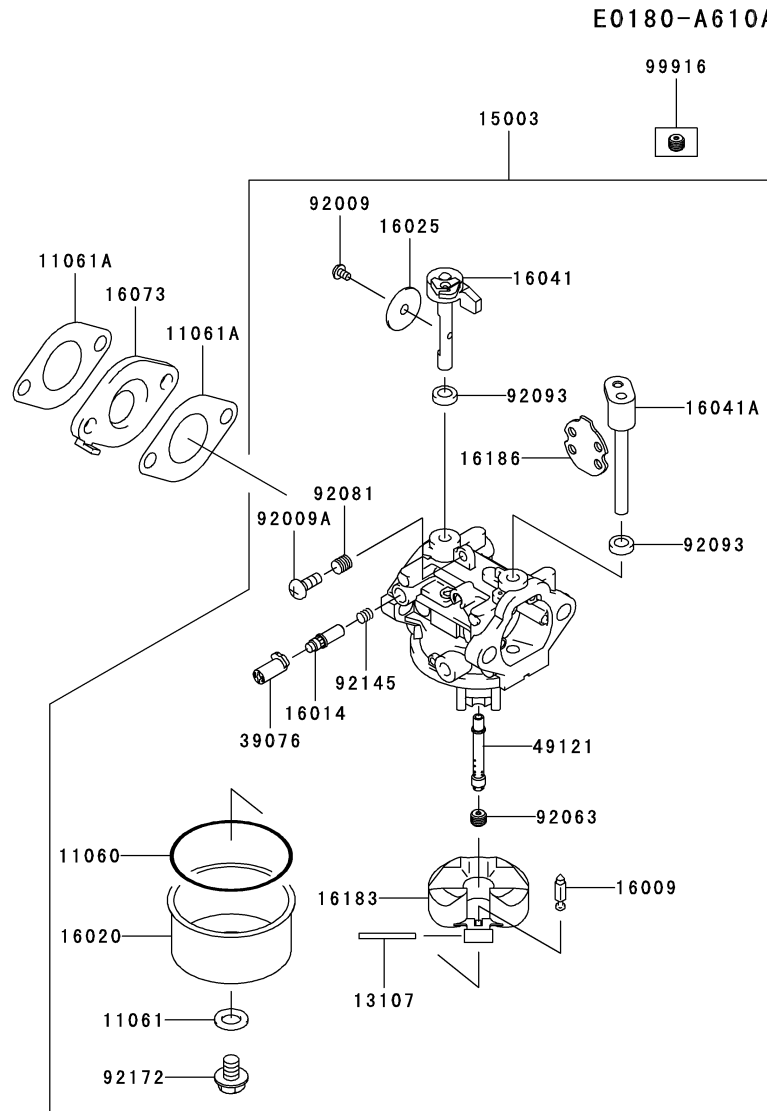

Ref. No.	Part No.	Description	Quantity
11060	11060-2190	GASKET	1
11061	11061-7010	GASKET,SCREW	1
11061A	11061-7015	GASKET,INSULATOR	2
13107	13107-7024	SHAFT	1
15003	15003-7132	CARBURETOR-ASSY	1
16009	16009-2136	NEEDLE-JET	1
16014	16014-7008	SCREW-PILOT AIR	1
16020	16020-7004	CHAMBER-FLOAT	1
16025	16025-7007	VALVE-THROTTLE	1
16041	16041-7019	SHAFT-CARBURETOR	1
16041A	16041-7020	SHAFT-CARBURETOR	1
16073	16073-7009	INSULATOR	1
16183	16183-2002	FLOAT-ASSY	1
16186	16186-7003	VALVE-ASSY-CHOKE	1
39076	39076-7001	LIMITER	1
49121	49121-7008	NOZZLE-MAIN	1
92009	92009-2083	SCREW	1
92009A	92009-2349	SCREW	1
92063	92063-7049	JET-MAIN,#74	1
92081	92081-2234	SPRING	1
92093	92093-2100	SEAL	2
92145	92145-7015	SPRING	1
92172	92172-7002	SCREW	1
99916	99916-7007	KIT-KHI PARTS,JET-MAIN	1

This catalog covers:

FJ151V- □ C50

This fig. covers:

09 AIR-FILTER/MUFFLER

E0190-A902A

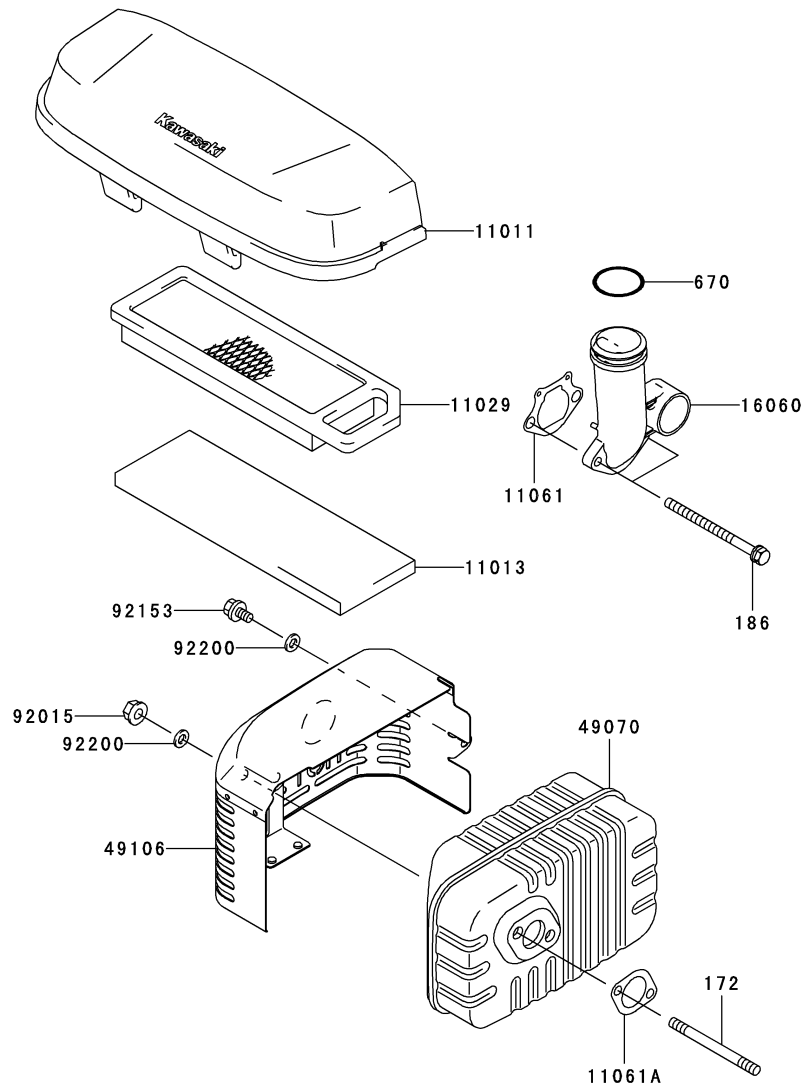

Ref. No.	Part No.	Description	Quantity
11011	11011-7025	CASE-AIR FILTER	1
11013	11013-7032	ELEMENT-AIR FILTER	1
11029	11029-7010	ELEMENT-ASSY-AIR FILTER	1
11061	11061-7012	GASKET,PIPE INTAKE	1
11061A	11061-7029	GASKET,MUFFLER	1
16060	16060-7012	PIPE-INTAKE	1
49070	49070-7022	MUFFLER-COMP	1
49106	49106-7017	COVER-MUFFLER	1
92015	92015-1193	NUT	2
92153	92153-7023	BOLT	1
92200	92200-7022	WASHER,6.4X12X1.6	3
172	172G0680	BOLT-STUD,6X80	2
186	186B0680	BOLT-UPSET-WP,6X80	2
670	670B3032	O RING,32MM	1

This catalog covers:

FJ151V- □ C50

This fig. covers:

10 FUEL-TANK/FUEL-VALVE

E0200-A544A

Ref. No.	Part No.	Description	A	Quantity
11060	11060-2145	GASKET	1	
51023	51023-7001	TAP-ASSY	*	
51023A	51023-7002	TAP-ASSY	1	
51049	51049-7002	CAP-TANK	1	
92170	92170-2009	CLAMP	*	
92170A	92170-2088	CLAMP	2	
92192	92192-7043	TUBE,6.35X12.7X255	1	
92192A	92192-7060	TUBE,6.2X13.2X255	*	

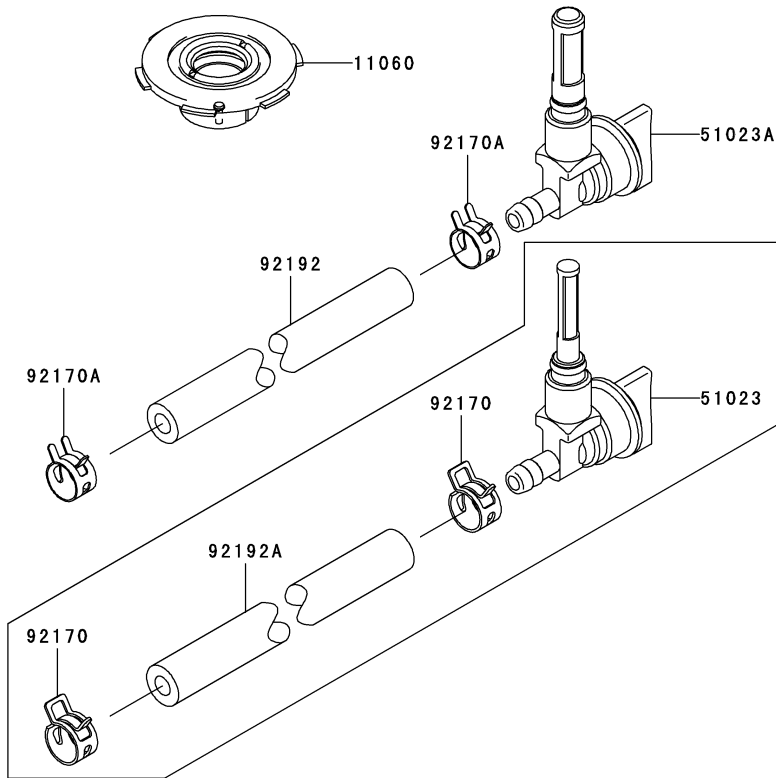
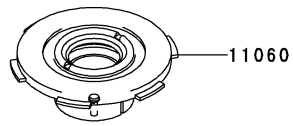
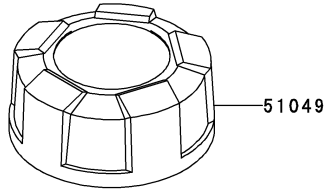

This catalog covers:
FJ151V- □ C50

11

This fig. covers:
STARTER

E0210-A276E

Ref. No.	Part No.	Description	Quantity
46075	46075-7002	GRIP	1
49088	49088-7022	STARTER-RECOIL	1
59106	59106-7006	ROPE,1500MM	1
92153	92153-7021	BOLT,M6	4

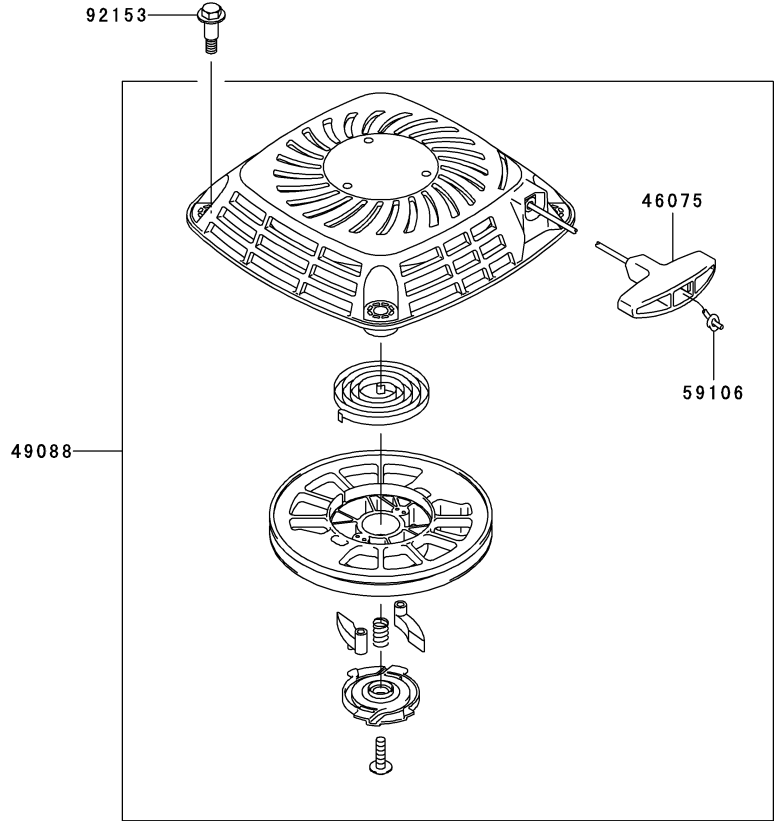

This catalog covers:

FJ151V- □ C50

12

This fig. covers:

LABEL

F0290-B292A

Ref. No.	Part No.	Description	Quantity
56033	56033-7003	LABEL-MANUAL	1
56070	56070-7001	LABEL-WARNING	1
56080	56080-7029	LABEL-BRAND	1

56033

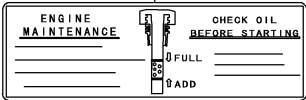

56070



56080



This catalog covers:

FJ151V- □ C50

This fig. covers:

PART NAME INDEX

AIR-FILTER/MUFFLER.....	09
CARBURETOR.....	08
CONTROL-EQUIPMENT.....	07
COOLING-EQUIPMENT.....	05
CYLINDER/CRANKCASE	01
ELECTRIC-EQUIPMENT.....	06
FUEL-TANK/FUEL-VALVE	10
LABEL.....	12
LUBRICATION-EQUIPMENT.....	04
PISTON/CRANKSHAFT	02
STARTER.....	11
VALVE/CAMSHAFT	03

This catalog covers:

FJ151V- □ C50

This fig. covers:

NUMERICAL PARTS INDEX

Part No.	Fig No.	Part No.	Fig No.	Part No.	Fig No.	Part No.	Fig No.	Part No.	Fig No.
11004-7020	01	16060-7012	09	92037-2209	07				
11008-7025	01	16073-2192	06	92038-2077	06				
11011-7025	09	16073-7009	08	92043-7001	01				
11013-7032	09	16126-7014	01	92043-7006	03				
11022-7005	01	16146-7018	05	92049-7008	01				
11029-7010	09	16154-7002	04	92055-2151	04				
11053-7009	05	16154-7004	03	92063-7049	08				
11060-2145	10	16169-7011	07	92070-2088	06				
11060-2190	08	16171-7015	07	92081-2234	08				
11061-7010	08	16183-2002	08	92093-2100	08				
11061-7012	09	16186-7003	08	92143-2135	07				
11061-7015	08	172G0680	09	92144-2266	07				
11061-7023	01	186B0680	09	92145-7015	08				
11061-7029	09	21083-7009	03	92145-7016	03				
11061-7030	04	21169-2071	06	92145-7025	07				
11061-7031	01	21171-7021	06	92145-7032	07				
11061-7051	01	21194-7024	06	92150-2182	07				
12004-7005	03	214B0420	07	92151-7012	04				
12005-7006	03	214B0510	01	92153-7007	04				
12009-7001	03	26011-7013	06	92153-7007	06				
12011-2056	03	311B0400	06	92153-7012	06				
12016-7008	03	39003-7002	07	92153-7016	04				
12032-7001	03	39076-7001	08	92153-7019	03				
12043-7005	03	39129-7014	07	92153-7021	11				
13001-7009	02	39182-7005	07	92153-7023	09				
13002-7001	02	410B0400	06	92153-7030	06				
13008-6065	02	42036-2051	07	92170-1577	04				
13031-7066	02	46075-7002	11	92170-2009	10				
13042-7006	03	49070-7022	09	92170-2088	10				
13070-7009	03	49078-7001	03	92172-7002	08				
130B0612	01	49088-7022	11	92191-7025	01				
130B0612	04	49103-7005	07	92192-7043	10				
130B0612	05	49106-7017	09	92192-7060	10				
130B0612	07	49110-7002	07	92200-2029	07				
130B0618	07	49120-7046	01	92200-2036	07				
130B0620	06	49121-7008	08	92200-7022	09				
130G0625	01	51023-7001	10	99916-7007	08				
130G0630	02	51023-7002	10						
130G0635	01	51049-7002	10						
130T0840	01	551A0612	01						
13107-7024	08	554A0600	07						
13116-7003	03	56033-7003	12						
13168-7020	07	56070-7001	12						
13168-7022	07	56080-7029	12						
13251-7011	02	59041-7009	05						
13280-7001	05	59066-7016	05						
14037-7017	05	59106-7006	11						
14041-7004	01	59231-7004	04						
14075-7007	04	670B3032	09						
14090-2108	06	670D2016	04						
14091-7010	01	92002-2269	07						
14091-7011	04	92009-2083	08						
14091-7036	06	92009-2341	03						
15003-7132	08	92009-2349	08						
16009-2136	08	92015-1193	07						
16014-7008	08	92015-1193	09						
16020-7004	08	92015-2051	07						
16025-7007	08	92015-2253	03						
16041-7019	08	92022-2372	07						
16041-7020	08	92033-7005	02						